

II EDIZIONE

MOLECULAR
BIOLOGY



Distributed by

 **BIOMEDICA**
www.bmgrp.eu

Euro  *Clone*[®]



Index

Introduction	4
1. Nucleic Acids Isolation Systems	6
2. Polymerases and Amplification	12
PCR.....	14
qPCR.....	15
RT-PCR.....	16
Reagents	17
3. Nucleic Acids Electrophoresis	20
Agaroses.....	22
Reagents for nucleic acids electrophoresis	25
4. Proteins Quantitation, Electrophoresis and Western Blotting	28
Protein Quantitation	30
Protein Molecular Weight Markers.....	31
Chemiluminescent Substrates for Western Blotting	32
Stripping.....	35
5. Plastic for Molecular Biology	36
FrameStar® Plates.....	38
Standard Plates	43
PCR Tubes & Strips.....	45
Adhesive Sealing Films & Foils.....	47
Heat Sealing Films & Foils.....	49
6. Primo® mechanical pipettes and Primo® tips	54
Primo® Mechanical pipettes.....	56
Primo® Tips	58
7. Services	60
8. Technical Appendix	64
Tips compatibility chart	70

The background of the page is a vibrant, abstract pattern of organic, flowing shapes in various shades of orange and red. The shapes are interconnected and resemble liquid droplets or cells, creating a sense of movement and depth. The colors range from bright yellow-orange to deep, saturated red, with some areas appearing more translucent than others.

INTRODUCTION

Since our establishment in the early 80's, Euroclone has given scientists a valuable opportunity to gain access to a world of products and equipment in Biotechnology.

During more than three decades of experience, our Company has evolved into a modern supplier of up-to-date and own-branded products, pursuing affordability and quality: all manufacturing procedures are strictly regulated with raw materials, bulks and final products undergoing stringent controls.

Euroclone provides innovative products, services and solutions for Molecular and Cell Biology, Genomics, Proteomics, Cytogenetics and Agro-Food Diagnostics.

From the choice of high-quality products to the after sales service, Euroclone is your reliable and solid partner for your scientific challenges.

In 2019 Euroclone is acquired by AddLife AB becoming part of an important international group. This step ensure continuity and further expansion of the company in the Italian market and in the export of the proprietary private lines, key and distinctive element of the identity of Euroclone.



1

NUCLEIC ACIDS ISOLATION SYSTEMS

Nucleic acids isolation is a crucial step in many experimental workflows. Our range of fully validated kits have been developed for use with diverse starting materials to ensure fast isolation of highly purified nucleic acids.

- ✓ Fast and easy protocols
- ✓ High quality and yields
- ✓ Cost effective

Nucleic Acids Isolation Systems

TriFast™ II - Nucleic Acids Isolation Reagent

TriFast™ II is a ready-to-use reagent for the extraction of RNA, DNA and proteins from a variety of starting materials. Used in conjunction with chloroform extraction, it allows the isolation of RNA, DNA and proteins from the same sample.

This method for purifying nucleic acids does not exclude very small or very large molecules and it is therefore suitable for studies of miRNAs or mRNAs. Additionally, this protocol produces high quality RNA suitable for applications such as cDNA synthesis and Real Time-PCR, Northern Blot or dot blot hybridization. DNA is suitable for use in enzymatic reactions such as restriction digestions or ligations, DNA sequencing, PCR, Southern Blot. The purified proteins can be used for Western Blot analysis.

Features

- Purification: RNA, DNA and proteins
- Format: Reagent + phenol/chloroform
- Starting materials: Wide ranging
- Starting Quantity: Scalable
- Expected Yield: Up to 7 µg/mg tissue
- Protocol time: 1+ hours

Protocol at-a-glance

- ✓ Homogenization and lysis of the sample with TriFast™
- ✓ Centrifugation
- ✓ Addition of chloroform and RNA extraction from the upper phase
- ✓ RNA precipitation and resuspension
- ✓ DNA extraction from the interphase/organic phase
- ✓ DNA precipitation and resuspension
- ✓ Protein extraction from the ethanol/phenol phase
- ✓ Protein purification

Expected Yields

RNA and DNA from tissue

Tissue	RNA	DNA
Liver	6-10 µg/mg	3-4 µg/mg
Kidney	3-4 µg/mg	3-4 µg/mg
Skeletal muscle	1-1,5 µg/mg	2-3 µg/mg
Brain	1-1,5 µg/mg	2-3 µg/mg
Placenta	1-4 µg/mg	2-3 µg/mg

RNA and DNA from cell culture

Cell Type	RNA	DNA
Epithelial cells	8-15 µg/10 ⁶ cells	5-7 µg/10 ⁶ cells
Fibroblast	5-7 µg/10 ⁶ cells	5-7 µg/10 ⁶ cells

Ordering information

Cat. Num.	Description	Size
EMR507100	TriFast™ II - Nucleic Acids Isolation Reagent	100 ml
EMR507200	TriFast™ II - Nucleic Acids Isolation Reagent	200 ml

Storage and Stability 6 months at 4°C

Shipping Blue Ice

DirectFAST

For a quick purification of high-quality (DNA-free) total RNA directly from TriFast™ II reagent, bypassing phase separation and precipitation procedures, TriFast™ II is available with Direct-zol RNA MiniPrep spin columns from our partner **Zymo Research**.

Obtained RNA is ultra-pure and NGS-ready; no phenol carryover or DNA contamination (DNase I included).

Features

- Purification: total RNA, including small RNAs (>17 nt)
- Format: Trireagent + spin-column
- Starting materials: a variety of sample sources
- Starting Quantity: DirectFAST up to 5×10^6 cells or 25 mg tissue; DirectFAST Plus up to 1×10^7 cells or 50 mg tissue
- Binding capacity: DirectFAST up to 50 µg; DirectFAST Plus up to 100 µg
- Elution volume: DirectFAST 25 µl; DirectFAST Plus 50 µl
- Protocol time: 7 minutes (sample preparation not included)

Protocol at-a-glance

- ✓ Apply a prepared sample in TriFast™ II directly to the Direct-zol-Spin Column
- ✓ Bind
- ✓ Wash
- ✓ Elute the RNA

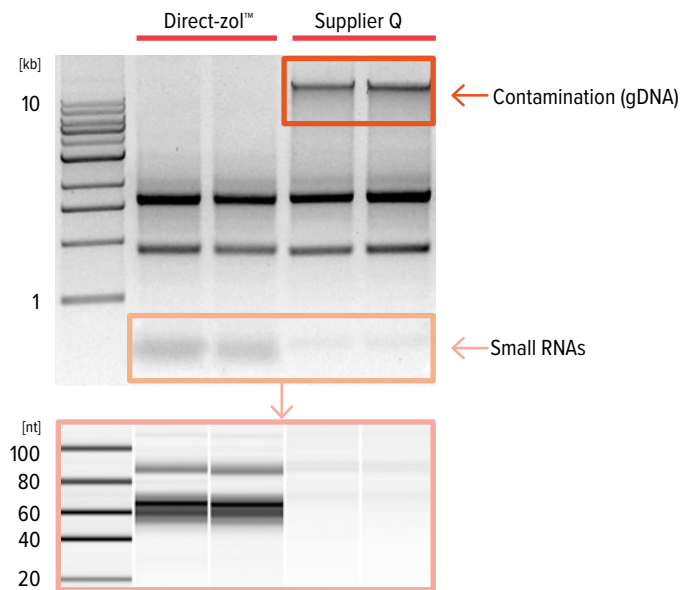

High-quality intact small and large RNAs are efficiently recovered using TriFast™ II and Direct-zol™ RNA Kit compared to using a Supplier Q Kit. RNA is DNA-free and ready for all downstream applications including NGS.



Bind RNA directly to a Direct-zol™ RNA Spin Column.

Ordering information

Cat. Num.	Description	Size
EMR527100	DirectFAST (Direct-zol™ RNA MiniPrep + TriFast™ II)	100 prep
EMR527200	DirectFAST (Direct-zol™ RNA MiniPrep + TriFast™ II)	200 prep
EMR528100	DirectFAST Plus (Direct-zol™ RNA MiniPrep Plus + TriFast™ II)	100 prep
EMR528200	DirectFAST Plus (Direct-zol™ RNA MiniPrep Plus + TriFast™ II)	200 prep

Storage and Stability 1 year at Room Temperature (except TriFast™ II at 4°C)

Shipping Room Temperature

EuroSAP - PCR Enzymatic Clean-up kit

EuroSAP is a quick and efficient PCR clean-up kit designed to remove primers and nucleotides from PCR products. It is based on the activity of two hydrolytic enzymes, recombinant Shrimp Alkaline Phosphatase (SAP) and Exonuclease I (Exo I); the combined action of these enzymes ensures complete dephosphorylation of dNTPs and degradation of residual primers. The reagents are active in commonly used PCR buffers and eliminates the need for buffer exchange. Purified DNA is ready for all downstream applications, such as sequencing, genotyping, cloning or SNP analysis.

This enzymatic protocol yields 100% product recovery for even very short PCR products and it is compatible with automatic processes.

Features

- Purification: DNA from PCR reaction mixes
- Format: Two reagents kit
- Starting materials: PCR reaction mixes
- Starting quantity: Scalable
- Protocol time: 15 min

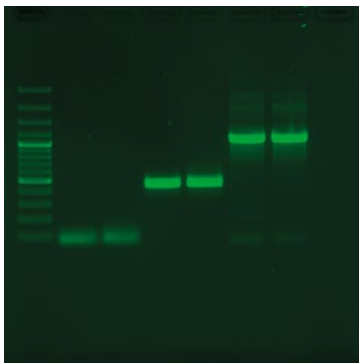

Total recovery of intact PCR product: Agarose gel showing three different PCR products before and after EuroSAP treatment. No loss of PCR product was detected even with small fragments.

Protocol at-a-glance

- ✓ Addition of SAP and Exo I to PCR mix
- ✓ Incubation at 37°C
- ✓ Heat inactivation at 80°C

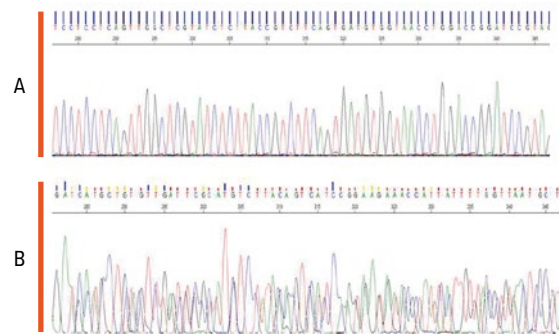

Importance of PCR clean-up before sequencing: Two samples of PCR products were either treated (panel A) or untreated (panel B) with EuroSAP kit. The enzymatic clean-up results in significant improvement of overall sequence length and quality.

Ordering information

Cat. Num.	Description	Size
EMR520500	EuroSAP PCR Enzymatic Clean-Up Kit	500 rxn (500 µl SAP, 500 µl Exo I)
EMR520001	EuroSAP PCR Enzymatic Clean-up Kit	1000 rxn (2 x 500 µl SAP 2 U/µl, 2 x 500 µl Exo I 10 U/µl)
EMR520002	EuroSAP PCR Enzymatic Clean-Up Kit	2000 rxn (4 x 500 µl SAP 2 U/µl, 4 x 500 µl Exo I 10 U/µl)

Storage and Stability 12 months at -20°C

Shipping Dry ice

RELATED PRODUCTS

PCR	pag. 14
qPCR	pag. 15
RT-PCR	pag. 16
Agaroses	pag. 22 - 24
DNA ladders	pag. 25, 26

2

POLYMERASES
AND
AMPLIFICATION

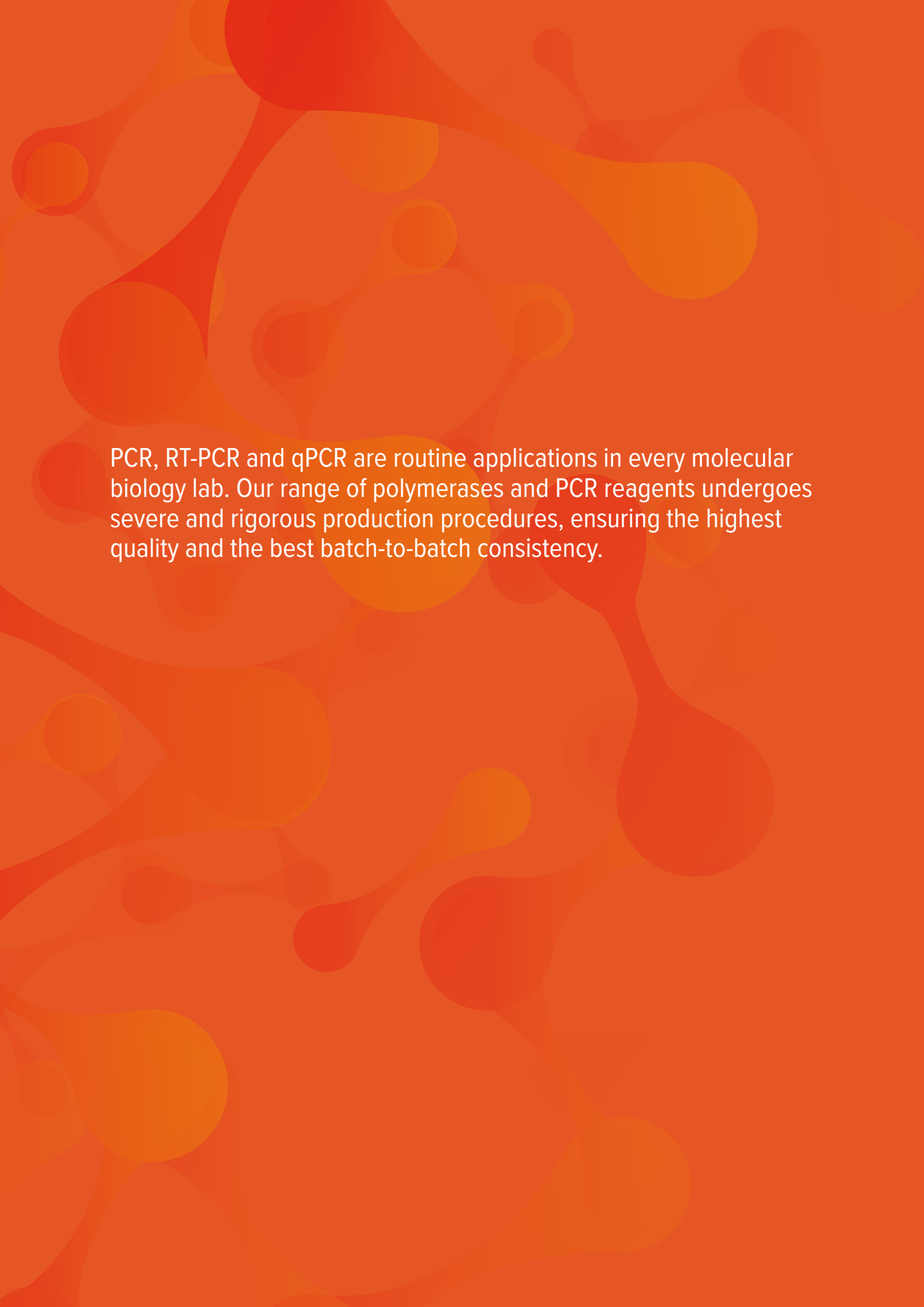
The background of the page is a solid orange color with a pattern of overlapping, organic, teardrop-like shapes in various shades of orange and yellow. These shapes vary in size and orientation, creating a dynamic and textured visual effect.

PCR, RT-PCR and qPCR are routine applications in every molecular biology lab. Our range of polymerases and PCR reagents undergoes severe and rigorous production procedures, ensuring the highest quality and the best batch-to-batch consistency.

PCR

Wonder Taq and Wonder Taq Hot start

Wonder Taq is a recombinant thermostable DNA polymerase engineered to give robust amplification and high yield with different PCR templates. Wonder Taq DNA Polymerase is supplied with an optimized reaction buffer already containing dNTPs, MgCl₂ and enhancers, avoiding the need of optimizing the reaction conditions.

In the Hot Start version, the enzyme is complexed with a monoclonal antibody blocking the polymerase activity at room temperature and preventing non-specific amplification. Activation occurs at 70°C, during the first step of denaturation.

Features

- Amplicon size: Up to 5 kb
- Resulting ends: A-tail
- Units per reaction (50 µl): 1.25 - 5
- Reaction Buffer: 5X, containing dNTPs, MgCl₂ and enhancers

Applications

- ✓ Standard PCR
- ✓ High-yield PCR
- ✓ Fast PCR
- ✓ Colony PCR
- ✓ TA cloning
- ✓ Genotyping
- ✓ GC-rich amplification

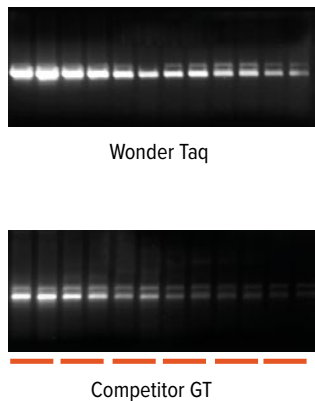

Increased yield with GC-rich targets (61% GC). Amplification of a 450 bp fragment from serial dilutions of human genomic DNA (from 1 µg to 12,5 ng) with Wonder Taq (upper panel) or a competitor enzyme (lower panel).

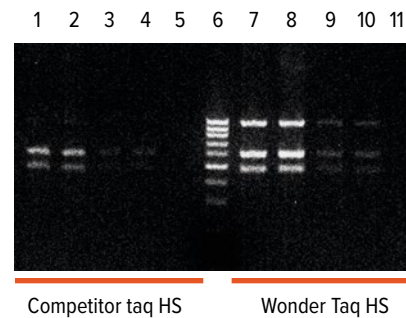

Higher yield in multiplex amplification. Amplification of 477 bp, 489 bp and 961 bp fragments from 2 different samples of human genomic DNA were carried out using either Wonder Taq HS or a competitor HS enzyme. Lanes 1;7 and 2;8 : undiluted sample A and B respectively. Lanes 3;9 and 4;10 : 1/10 dilution of sample A and B respectively.

Ordering information

Cat. Num.	Description	Size
EME020001	Wonder Taq	1000 units
EME023500	Wonder Taq Hot Start	500 units

Storage and Stability 2 years at -20°C

Shipping Blue Ice

qPCR

FluoCycle II™ Master Mix for Real Time PCR

Euroclone qPCR master mixes are ready-to-use 2X solutions optimized for Real Time PCR. The master mixes include Wonder Taq Hot Start DNA polymerase and dNTPs in an optimized buffer.

The SYBR® Master Mix contains the green intercalating dye allowing DNA detection and analysis without using sequence-specific probes. Only template and primers need to be added.

The Master Mix for Probe has been formulated for the detection of amplicon product with sequence specific fluorogenic probes. Primers, probe and template must be added before use.

Features

- Wide linear range
- Detection of low copy number targets
- Highly reproducibility and minimum hands-on time
- High specificity

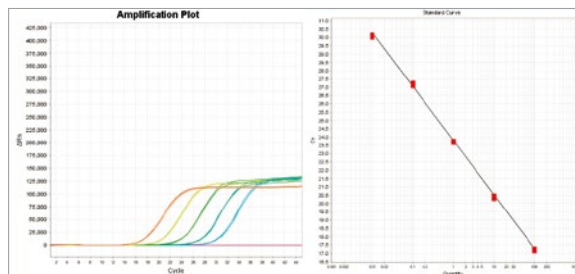

Linear target amplification with a dynamic range across 5 orders of magnitude of input. Amplification plot and standard curve from real-time PCR for a dilution series of human CLUSTERIN cDNA amplified in 3 replicate reactions using the Step One Plus Real-Time PCR System, FluoCycle II Master Mix for probe and specific clusterin probe.

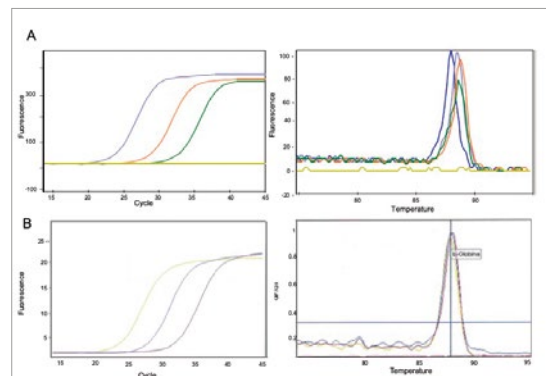

Specific and reproducible qPCR with 2 different instruments using Euroclone FluoCycle II™ Master Mix. Amplification of the human β -globin gene was performed on serial dilutions of genomic DNA. Instruments used: A: Cepheid® SmartCycler®. B: Corbett RotorGene® 3000.

Ordering information

Cat. Num.	Description	Size
ERD001250BIM	FluoCycle II™ Master Mix for Probe	500 rxn (reaction volume 25 μ l)
ERD002250BIM	FluoCycle II™ SYBR® Master Mix	500 rxn (reaction volume 25 μ l)

Storage and Stability 1 year at -20°C

Shipping Blue Ice

Notice to purchaser: limited license

For Research Use Only (RUO). Diagnostic uses under Roche patents require a separate license from Roche. No right under any patent claim (ex: Patents Nos. 5,210,015 and 5,487,972), no right to perform any patented method, and no right to perform commercial services of any kind, including without limitation reporting the results of purchaser's activities for a fee or other commercial consideration, is conveyed expressly, by implication, or by estoppel. Some applications this product is used in may require a license which is not provided by the purchase of this product. Users should obtain the license if required. Further information on purchasing licenses: Director of Licensing, Applied Biosystems, 850 Lincoln Centre Drive, Foster City, California 94404 USA.

RT-PCR

Wonder RT - cDNA Synthesis kit

NEW

Wonder RT kit is a rapid and very sensitive method for first strand cDNA synthesis. It is a two-components system: 1) an extremely efficient reverse transcriptase allows highly robust first strand synthesis and higher cDNA yields from a wide range of input RNA concentrations; 2) a 5x Reaction Buffer Mix provides highly optimized components for efficient reverse transcription.

Features

- Easy reaction set up: primers and dNTPs are included in the 5x Reaction Buffer Mix and RNase inhibitor is included in the Reverse Transcriptase Mix
- Unbiased: primers are composed of an optimized mixture of random hexamers and anchored oligo dT primers for complete 5' to 3' RNA sequence representation
- Fast: high-yield reverse transcription in as little as 25 minutes
- Robust: reliable reverse transcription even with complex templates or in the presence of inhibitors thanks to specific enhancers included in the 5x Reaction Buffer Mix
- Sensitive: down to 1 pg of input RNA and accurate detection of very low-copy targets

Applications

- ✓ Gene expression analysis
- ✓ Tissue biopsy analysis
- ✓ miRNA profiling/quantification
- ✓ RNA target detection
- ✓ Pathogen detection

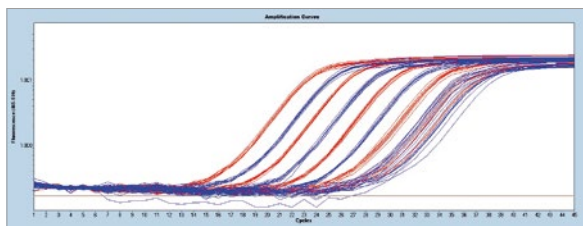

Speed and sensitivity. Wonder RT kit was used in first-strand cDNA synthesis reactions of total RNA, following the recommended reaction conditions. A 10-fold serial dilution of the cDNA was then used in qPCR reactions, using SYBR. The results illustrate that Wonder RT (red) is both faster and more sensitive than competitor Q (blue), as judged by the earlier Ct values and improved uniformity between standard curves of decreasing amounts of input RNA.

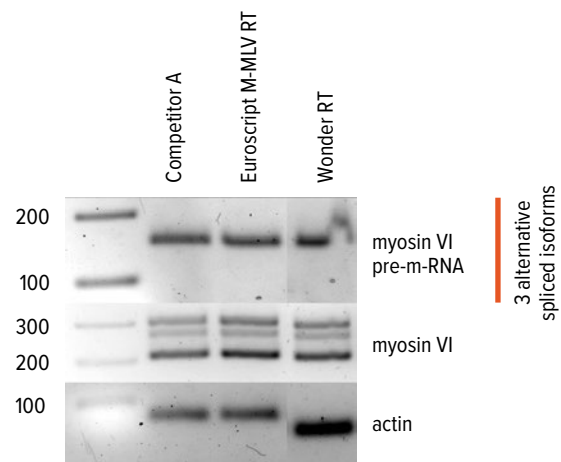

The yield and the intensity are similar between Wonder RT and our old Euroscript M-MLV-RT, in both case yield and intensity are superior than Competitor A. 2µl were used as a template in each PCR.

Ordering information

Cat. Num.	Description	Size*
EME037050	Wonder RT - cDNA Synthesis kit (50 rxn)	50 rxn
EME037250	Wonder RT - cDNA Synthesis kit (250 rxn)	5 x 50 rxn

*reaction volume 20 µl

Storage and Stability 2 years at -20°C

Shipping Dry Ice

Reagents

RNase inhibitor

RNase Inhibitor completely inhibits the activity of RNases A, B and C by non-covalent binding. It binds the RNases in a 1:1 ratio. It does not inhibit the RNases I, T1, T2, H, U1, U2 and CL3.

Ordering information

Cat. Num.	Description	Size
EMR436050	RNase Inhibitor	2000 units (50 µl)
EMR436250	RNase Inhibitor	10000 units (250 µl)

Storage and Stability 1 year at -20°C

Shipping Blue Ice

Oligo (dT)₂₀ Primer and Random Hexamers

Oligo (dT) Primer hybridizes to the poly(A) tail of mRNA and is used as primer for first stand cDNA synthesis with reverse transcriptases. Random Hexamers are a mixture of oligonucleotides representing all possible sequences for a hexamer.

Random Hexamers are used in DNA labelling by PCR (DOP-PCR) or cDNA synthesis by RT-PCR.

Ordering information

Cat. Num.	Description	Size
EMR433200	Oligo (dT) Primer 100 µM	200 µl
EMR433001	Oligo (dT) Primer 100 µM	1 ml
EMR428200	Random Hexamers 100 µM	200 µl
EMR428001	Random Hexamers 100 µM	1 ml

Storage and Stability 1 year at -20°C

Shipping Blue Ice

dNTPs

Euroclone's enzymatic dNTP manufacturing process and refined purification protocols ensure the highest quality of deoxynucleotides. All our dNTPs are ultrapure (> 99%) and quality checked by a set of PCR, RT-PCR and Klenow reactions.

Euroclone dNTPs are available as single bases, set or mix. Individual nucleotides are supplied as single ready-to-use 100 mM solutions or as a 4 x 250 µl set. The dNTP mix consist of a mixture of dATP, dCTP, dGTP and dTTP (final concentration of each nucleotide 10 or 25 mM).

Euroclone dNTPs have the highest purity, are free of strong PCR inhibiting contaminants as tetraphosphates and pyrophosphates. All lots are checked on HPLC for their purity using a sensitive acetonitrile gradient in 20 mM KH_2PO_4 , 2 mM TBA-SO_4 on a Eurospher-100 C18 RP-column (4 x 250 mm). Detection occurs at 254 nm.

Ordering information

Cat. Num.	Description	Size
EMR272025	dATP 100 mM Solution	250 µl (25 µmol)
EMR273025	dCTP 100 mM Solution	250 µl (25 µmol)
EMR274025	dGTP 100 mM Solution	250 µl (25 µmol)
EMR275025	dTTP 100 mM Solution	250 µl (25 µmol)
EMR276425	dNTP set	4 x 250 µl (4x25 µmol)
EMR276001	dNTP set	4 x 1 ml (4 x 100 µmol)
EMR415001	dNTP Mix 25 mM solution	1 ml (25 µmol)
EMR416200	dNTP Mix 10 mM solution	200 µl (2 µmol)
EMR416001	dNTP Mix 10 mM solution	1 ml (10 µmol)

Storage and Stability 1 year at -20°C

Shipping Blue Ice

NTPs

Nucleotide Triphosphates (NTPs) are available as 100 mM ready-to-use solution.

Our NTP solutions are optimized for in vitro transcription with the common polymerases and the major commercially available transcription kits.

Ordering information

Cat. Num.	Description	Size
EMR423001	ATP 100 mM solution	1 ml (100 µmol)
EMR424001	CTP 100 mM solution	1 ml (100 µmol)
EMR425001	GTP 100 mM solution	1 ml (100 µmol)
EMR426001	UTP 100 mM solution	1 ml (100 µmol)

Storage and Stability 1 year at -20°C

Shipping Blue Ice

RELATED PRODUCTS

Nucleic Acids Isolation Systems	pag. 6 - 11
Agaroses	pag. 22 - 24
DNA ladders	pag. 25, 26
Plastic for Molecular Biology	pag. 36 - 53

3

NUCLEIC
ACIDS
ELECTROPHORESIS

The background of the page is a solid orange color with a pattern of overlapping, organic, teardrop-like shapes in various shades of orange and yellow. These shapes are scattered across the page, creating a textured, abstract effect.

Separation of nucleic acids basing on their size on agarose gel is a very common analytical technique applied in several molecular biology process flows such as PCR amplification, sequencing, cloning, or blotting. Our selection of agaroses, stain and DNA ladders will help to achieve optimal results in every experiment.

Agaroses

Euroclone offers a complete selection of high-quality agaroses for standard and specific electrophoresis applications.

	Agarose LE	GellyPhor® LE	GellyPhor® LM	GellyPhor® ULTRA	GellyPhor® HR	GellyPhor® PFGE
DNA separation 1-50 kb	-	-	-	-	-	✓
DNA/RNA separation ≤1 kb	✓	✓	-	✓	✓	-
DNA/RNA separation ≥1 kb	✓	✓	✓	-	-	✓
DNA separation 20-800 bp	-	-	-	✓	-	-
Blotting	✓	✓	-	-	✓	✓
DNA finger printing	✓	✓	-	-	-	-
Nucleic Acid Recovery	✓	✓	✓	✓	✓	✓

Agarose LE Agarose for Nucleic Acids routine screening electrophoresis

Agarose LE is a multi-purpose agarose with low EEO and standard melting point, ideal for routine DNA and RNA gel electrophoresis and blotting. Its optimized gel strength makes gel processing and handling easy. It yields sharp DNA bands with high clarity and low background.

Technical Specification

- Gelling Temperature (1,5%): 36°C ± 1,5°C
- Moisture: ≤ 10%
- Gel strength (1%): ≥ 1200 g/cm²
- EEO: ≤ 0,13 (-m₁)
- Sulphate: ≤ 0,20%
- RNase/DNase Activity: None detected

Ordering information

Cat.	Description	Size
EMR920500	Agarose LE Agarose for Nucleic Acids routine screening electrophoresis	500 g

Storage and Stability 5 years at Room Temperature

Shipping Room Temperature

GellyPhor® LE

GellyPhor® LE is ideal for general nucleic acids preparative and analytical gel electrophoresis as well as for blotting.

This gel sharply resolves the different DNA fragments to be analyzed and provides consistent resolution from batch-to-batch. It forms high strength gels with low background upon staining with ethidium bromide or alternative safer reagents. Due to the low electroendosmosis value (EEO) of GellyPhor® LE, the DNA has a high electrophoretic mobility allowing shorter running time.

GellyPhor® LE agarose Quick Solving has a special particle size distribution, providing an easier and faster dissolution either by standard boiling or microwaving.

Technical Specification

- Gelling Temperature (dynamic measurement in 1.5% solution): 34 - 38°C
- Gel strength (1%): ≥ 1200 g/cm²
- EEO: ≤ 0.12 (-m₁)
- Sulphate: ≤ 0.14%
- Moisture: ≤ 8.5%
- Residue on ignition: ≤ 0.60%
- RNase/DNase Activity: None detected

Ordering information

Cat. Num.	Description	Size
EMR010100	GellyPhor® LE	100 g
EMR910500	GellyPhor® LE agarose Quick Solving	500 g
EMR010001	GellyPhor® LE	1 kg

Storage and Stability 5 years at Room Temperature

Shipping Room Temperature

GellyPhor® LM

GellyPhor® LM is a low melting temperature agarose. This molecular biology grade agarose produces gels with greater sieving properties and higher clarity than standard melting temperature agarose. The low melting temperature of GellyPhor® LM makes it ideal for preparative nucleic acids electrophoresis, while its low gelling temperature is perfect for cloning of tissue culture cells and viral plaque assays.

Technical Specification

- Gelling Temperature (dynamic measurement in 1.5% solution): 24 - 28°C
- Gel strength (1.5%): ≥ 500 g/cm²
- EEO: ≤ 0.12 (-m₁)
- Sulphate: $\leq 0.12\%$
- Moisture: $\leq 7\%$
- Melting Temperature (1.5%): $\leq 65.5^\circ\text{C}$
- RNase/DNase Activity: None detected

Ordering information

Cat. Num.	Description	Size
EMR911100	GellyPhor® LM	100 g

Storage and Stability 5 years at Room Temperature

Shipping Room Temperature

GellyPhor® HR

GellyPhor® HR is a molecular biology grade standard melting temperature agarose, that yields strong gels for fine resolution of small nucleic acids fragments. Performance testing of GellyPhor® HR ensures fine resolution of DNA fragments up to 1000 bp, though this agarose is capable of finely resolving DNA fragments ranging from 10 bp up to 1200 bp. GellyPhor® HR is designed for analytical electrophoresis.

Technical Specification

- Gelling Temperature (dynamic measurement in 3% solution): 35.5°C
- Gel strength: ≥ 600 g/cm² (for a 1.5% gel), ≥ 1500 g/cm² (for a 3% gel)
- EEO: ≤ 0.12 (-m)
- Sulphate: $\leq 0.11\%$
- Moisture: $\leq 7\%$
- Melting Temperature (3%): $\leq 80^\circ\text{C}$
- RNase/DNase Activity: None detected

Ranges of separation*

- 1.8%: 400 - 1200 bp
- 3%: 150 - 800 bp
- 4.5%: 15 - 400 bp

(* These ranges are approximate and have been calculated in TAE Buffer. To achieve the best resolution of GellyPhor® HR gels, they should be stored at 4°C/8°C for 30 minutes before use.

Ordering information

Cat. Num.	Description	Size
EMR912100	GellyPhor® HR	100 g

Storage and Stability 5 years at Room Temperature

Shipping Room Temperature

GellyPhor® ULTRA

GellyPhor® ULTRA is an intermediate melting temperature agarose that provides twice the resolution capabilities of the finest sieving agarose products. You can resolve DNA fragments, PCR and RT-PCR products differing in size by 2%, in the range of 20 bp to 800 bp, by horizontal gel electrophoresis (for example, a 200 bp DNA fragment can be separated from a 204 bp fragment). Using fast run protocols, DNA fragments differing in size by 1% can be resolved in as little as 1.5 hours in a 20 cm long horizontal or vertical gel format. GellyPhor® ULTRA agarose gels (2% to 4%) approximate the resolution of polyacrylamide gels (4% to 8%).

Technical Specification

- Gelling Temperature (dynamic measurement in 3% solution): $\leq 36^{\circ}\text{C}$
- Gel strength (3%): $\geq 400\text{ g/cm}^2$
- EEO: $\leq 0.02 - 0,05$ (-m_r)
- Moisture: $\leq 10\%$
- Melting Temperature (3%): $\leq 75^{\circ}\text{C}$
- RNase/DNase Activity: None detected

Ordering information

Cat. Num.	Description	Size
EMR915100	GellyPhor® ULTRA	125 g

Storage and Stability 5 years at Room Temperature

Shipping Room Temperature

GellyPhor® PFGE

GellyPhor® PFGE is a very high gel strength, low EEO, standard gelling temperature agarose. Due to its high gel strength, this agarose can be used for the preparation of low percentage gels for the analysis not only of high molecular weight nucleic acids (such as chromosomes), but also of large-sized particles such as viruses and ribosomes.

Technical Specification

- Gelling Temperature (dynamic measurement in 1.5% solution): $\leq 36 \pm 1.5^{\circ}\text{C}$
- Gel strength : $\geq 1600\text{ g/cm}^2$ (for a 1% gel), $\geq 3000\text{ g/cm}^2$ (for a 1.5% gel)
- EEO: < 0.13 (-m_r)
- Moisture: $\leq 7\%$
- Melting Temperature (1.5%): $\leq 1.5^{\circ}\text{C}$
- RNase/DNase Activity: None detected

Ordering information

Cat. Num.	Description	Size
EMR916100	GellyPhor® PFGE	100 g

Storage and Stability 5 years at Room Temperature

Shipping Room Temperature

Reagents for nucleic acids electrophoresis

Gel Staining

EuroSafe - Nucleic Acid Stain

EuroSafe Nucleic Acid Staining Solution (20,000x) is a safe nucleic acid stain, alternative to the traditional ethidium bromide (EtBr) staining for the detection of nucleic acid in agarose gels. It emits green fluorescence when bound to DNA or RNA. This stain has two fluorescence excitation maxima when bound to nucleic acid, one centered at 309 nm and another at 419 nm. In addition, it has one visible excitation at 514 nm. The fluorescence emission of EuroSafe bound to DNA is centered at 537 nm. EuroSafe is as sensitive as EtBr. Compared to EtBr, known as a strong mutagen, it causes much fewer mutations in the Ames test. In addition, EuroSafe Nucleic Acid Staining Solution (20,000x) has a negative result in mouse marrow chromophilous erythrocyte micronucleus test and mouse spermary spermatocyte chromosomal aberration test.

Features

- Used for detecting DNA e RNA
- Alternative to the ethidium bromide staining
- As sensitive as EtBr or more sensitive than that
- Less mutagenic than EtBr

Ordering information

Cat. Num.	Description	Size
EMR440001	EuroSafe	1 ml

Storage and Stability 5 years at Room Temperature

Shipping Room Temperature

DNA Ladders

Euroclone has three different DNA Ladders for sizing and approximate quantification of double-stranded DNA fragments such as PCR or restriction digestion products. The ladders have extremely sharp bands and reference bands with higher DNA content for easy orientation. They are designed to show virtually uniform spacing over a wide fragment range.

Features

- It is possible to approximate the mass of DNA in comparably intense samples of similar size
- No extraneous high molecular weight bands
- Value - load only 5 µl/lane
- Easy-to-identify reference bands

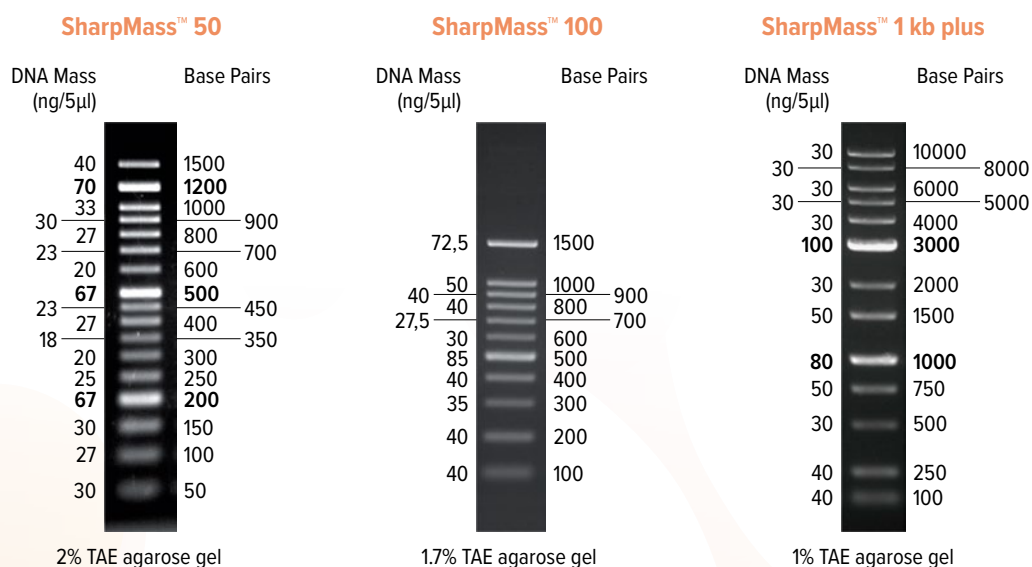

SharpMass™ 50 Ready-To-Load DNA Ladder

SharpMass™ 50 Ready-to-load DNA Ladder consists of 17 DNA fragments ranging from 50 bp to 1.5 kb. The 200, 500 and the 1200 base pair fragments have enhanced brightness and can be used as reference points. The fragment mix is supplied in ready-to-use format containing Orange G as tracking dye.

SharpMass™ 100 Ready-To-Load DNA Ladder

SharpMass™ 100 Ready-to-load DNA Ladder consists of 11 DNA fragments ranging from 100 bp to 1.5 kb. The 500 and the 1500 base pair fragments have enhanced brightness and can be used as reference points. The fragment mix is supplied in ready-to-use format containing orange and blue tracking dyes.

SharpMass™ 1 kb plus Ready-To-Load DNA Ladder

SharpMass™ 1 kb plus Ready-to-load DNA Ladder consists of 13 DNA fragments ranging from 0,10 kb to 10 kb. The 1000 bp and the 3000 bp base pair fragments have enhanced brightness and can be used as reference points. The fragment mix is supplied in ready-to-use format containing bromo-phenol blue and xylene cyanol FF tracking dyes.

Ordering information

Cat. Num.	Description	Size
EMR810100	SharpMass™ 50 - Ready-to-load DNA Ladder	100 lanes
EMR814100	SharpMass™ 100 - Ready-to-load DNA Ladder	100 lanes
EMR816100	SharpMass™ 1 kb plus - Ready-to-load DNA Ladder	100 lanes

Storage and Stability 6 months at 25°C or 12 months at 4°C. Maximal stability (24 months) is achieved at -20°C.

Shipping Blue Ice

RELATED PRODUCTS

Nucleic Acids Isolation Systems	pag. 6 - 11
PCR	pag. 14
RT-PCR	pag. 16

4

PROTEINS
QUANTITATION,
ELECTROPHORESIS
AND WESTERN
BLOTTING

The background of the page is a solid orange color with a pattern of overlapping, organic, teardrop-like shapes in various shades of orange and yellow. These shapes vary in size and orientation, creating a dynamic and textured visual effect.

The study of proteins' expression and of their role in cells is one of the main goals in every research program. Our essential products for protein research cover proteins quantitation, electrophoresis and Western Blotting offering reliability, efficiency and reproducibility.

Protein Quantitation

Euroclone protein assay kits are based on the use of bicinchoninic acid (BCA) for the rapid and sensitive detection and quantitation of total protein content. The BCA method is faster and easier than Lowry, with much greater tolerance to interference from non-ionic detergents and buffer salts.

The BCA method combines the biuret reaction, i.e. the reduction of Cu^{2+} ions to Cu^+ by proteins in an alkaline medium with complexation of the latter with bicinchoninic acid. The purple-colored Cu-BCA complex displays a strong absorbance at 562 nm which is proportional to protein concentration over a broad working range (20-2.000 $\mu\text{g/ml}$ for Quantum Protein and 0.5-20 $\mu\text{g/ml}$ for Quantum Micro Protein).

Protein concentrations are generally determined with reference to standards of a common protein such as Bovine Serum Albumin (BSA). If a more accurate quantitation of an unknown protein is required, the calibration curve has to be constructed using a protein similar to the unknown one.

Quantum Protein & Quantum Micro Protein Assays

Features

- Easy to use
- Compatible with most common ionic and non-ionic detergents
- Faster than Lowry method
- Linear working range from 20-2.000 $\mu\text{g/ml}$ (BCA) or 0.5-20 $\mu\text{g/ml}$ (micro BCA)
- Working solution extremely stable
- Protocol flexibility to increase the sensitivity of the assay
- Cuvette or microplate format

Protocol at a glance (Quantum Protein)

- ✓ Prepare working solution (reagent A plus B ratio 5:1)
- ✓ Add 2 ml working reagent to 100 μl sample
- ✓ Incubate 30 min at 37°C
- ✓ Read at 562 nm

Ordering information

Cat. Num.	Description	Size
EMP014250	QuantumProtein Bicinchoninic Protein Assay Kit (Linear working range 20-2000 $\mu\text{g/ml}$)	250 tube assays
EMP014500	QuantumProtein Bicinchoninic Protein Assay Kit (Linear working range 20-2000 $\mu\text{g/ml}$)	500 tube assays
EMP015480	QuantumMicroProtein Bicinchoninic Protein Assay Kit for dilute samples (Linear working range 0.5-20 $\mu\text{g/ml}$)	480 tube assays

Storage and Stability 1 year at Room Temperature

Shipping Room Temperature

Protein Molecular Weight Markers

Prestained SharpMass™ VI and VII are designed for monitoring protein separation during SDS-polyacrylamide gel electrophoresis, verification of Western blot transfer efficiency on membranes (PVDF, nylon, or nitrocellulose) and for approximating the protein size. Markers are supplied in gel loading buffer and are ready to use: no need of heating, diluting, adding reducing agent before loading.

Features

- Ready-to-load
- Broad range of bands
- Colored reference bands
- Stable at Room Temperature for up to 2 weeks

Prestained Protein SharpMass™ VI

Prestained Protein SharpMass™ VI is a three-color protein standard with 13 pre-stained proteins covering a wide range molecular weights from 5 to 245 kDa when separated on SDS-PAGE (Tris-glycine buffer). Proteins are covalently coupled with a blue chromophore except for two reference bands (one green and one red band at 25 kDa and 75 kDa respectively).

Prestained Protein SharpMass™ VII

Prestained Protein SharpMass™ VII is a three-color protein standard with 10 pre-stained proteins covering a wide range molecular weights from 6,5 kDa to 270 kDa when separated on SDS-PAGE (Tris-glycine buffer). Proteins are covalently coupled with a blue chromophore except for three reference bands (two orange bands at 30 kDa and 270 kDa and one green band at 52 kDa).

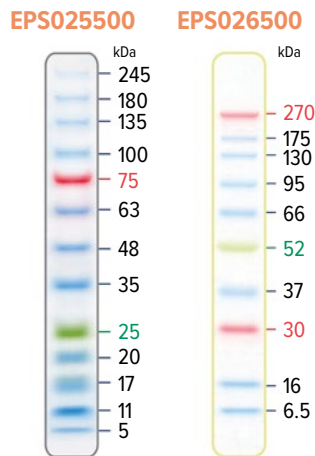

Bands pattern of prestained protein SharpMass™ VI and SharpMass™ VII in 20% Tris-Glycine SDS-Page.

Ordering information

Cat. Num.	Description	Size
EPS025500	Prestained Protein SharpMass™ VI	500 µl
EPS026500	Prestained Protein SharpMass™ VII	500 µl

Storage and Stability Up to 2 weeks at RT. Up to 3 months at 4°C. 24 months at -20°C.

Shipping Blue ice

Chemiluminescent Substrates for Western Blotting

Euroclone offers a complete range of chemiluminescent substrates to satisfy any need in terms of reliability, sensitivity and signal duration. In addition, all chemicals contained in these substrates have been carefully selected for safety: none of the components has been reported to be hazardous to human health.

	ECL Star Cat. EMP001005	LiteUP Cat. EMP002005	LiteAblot EXTEND Cat. EMP013001	LiteAblot TURBO Cat. EMP012001
Signal Intensity				
Sensitivity	Picograms	Picograms to mid femtograms	Mid femtograms	Low femtograms
Signal Duration	Up to 4 hrs	Up to 4 hrs	24 hrs	8 hrs
Volume	250 ml +250 ml	250 ml + 250 ml	50 ml + 50 ml	50 ml + 50 ml
Recommended Antibodies dilutions (1 mg/ml stock solution)	Primary Ab: 1/100-1/5000 Secondary Ab: 1/1000-1/15000	Primary Ab: 1/1000-1/15000 Secondary Ab: 1/25000-1/150000	Primary Ab: 1/1000-1/50.000 Secondary Ab: 1/50000-1/250000	Primary Ab: 10-200 ng/ml Secondary Ab: 1/100000-1/500000

ECL Star Enhanced Chemiluminescent Substrate

ECL Star Enhanced Chemiluminescent Substrate is a two-components, non-radioactive light emitting substrate for the detection of picograms amounts of immobilized specific antigens, conjugated directly or indirectly with horseradish peroxidase HRP-labelled antibodies. It is an excellent chemiluminescent reagent for daily routine WB analysis.

Features

- Optimized sensitivity
- Low Background
- Working solution stable up to 5 days
- Signal duration up to 4 hours

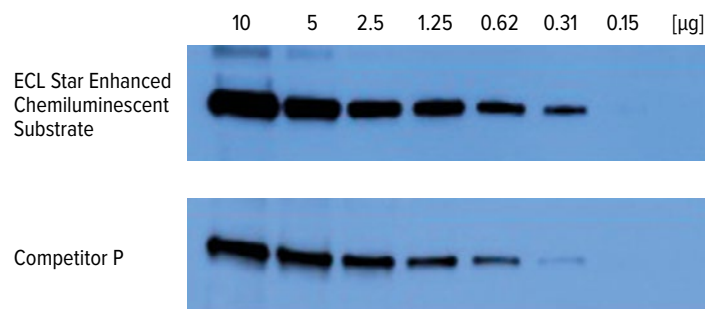

Actin protein expression in a serial dilution of HeLa cells lysate was detected by Western blotting. Image acquisition by imager, exposure time of 60 seconds. ECL Star enhanced chemiluminescent substrate shows a high signal intensity and low background, allowing to achieve better performance than other competitors.

Ordering information

Cat. Num.	Description	Size
EMP001005	ECL Star Enhanced Chemiluminescent Substrate	250 ml + 250 ml (5000 cm ²)

Storage and Stability 1 year at room temperature

Shipping Room Temperature

LiteUP WB Chemiluminescent Substrate

LiteUP WB Chemiluminescent Substrate is a two-component, a non-radioactive light emitting substrate for the detection of amounts ranging from picograms to mid-femtograms of immobilized specific antigens, conjugated directly or indirectly with HRP-labelled antibodies. It gives optimal performances when the Western Blot needs a high and stable signal intensity and a good sensitivity on medium expressed proteins.

Features

- High signal-to-noise ratio
- Storage at Room Temperature
- Working solution stable up to 3 days
- Signal duration up to 4 hours
- Cost-effective

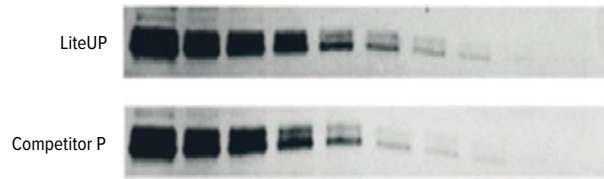

Analysis of MAP kinase expression (ERK 1/2) in a serial dilution of HeLa cell lysate; image acquisition by imager; exposure time of 120 seconds.

Ordering information

Cat. Num.	Description	Size
EMP002005	LiteUP WB Chemiluminescent Substrate	250 ml + 250 ml (5000 cm ²)

Storage and Stability 1 year at room temperature

Shipping Room Temperature

LiteAblot® EXTEND - Long Lasting Chemiluminescent Substrate

LiteAblot® EXTEND is two-components substrate and has been specifically formulated to provide an intense and extremely stable chemiluminescent signal. For this reason, this product is particularly suggested to customers using imaging systems based on cooled charge coupled device (CCD) technology. Considering the high sensitivity of this substrate compared to standard "ECL-like" products, it can be necessary to dilute primary and secondary antibodies much further.

Features

- Excellent sensitivity
- Long lasting signal, stable up to 24 hours

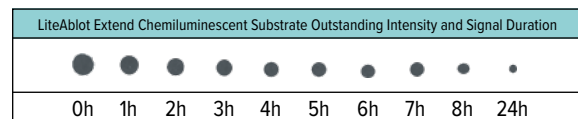

Images of a 50 pg dot blot incubated 5 minutes with LiteAblot® EXTEND. The signal has been captured with a NighOwl Luminograph (Berthold Technologies). Readings were taken at the indicated times after incubation, with an exposure time of 10 minutes, except for the last reading (1 hour).

Ordering information

Cat. Num.	Description	Size
EMP013001	LiteAblot® EXTEND	50 ml + 50 ml (1000 cm ²)

Storage and Stability 1 year at 4°C

Shipping Room Temperature

LiteAblot® TURBO - Extra Sensitive Chemiluminescent Substrate

LiteAblot® TURBO is Euroclone's chemiluminescent substrate with the highest sensitivity allowing the detection of very low amounts of proteins. It is a two-components reagent. Due to the extreme sensitivity of the substrate it is critical to optimize the primary and secondary antibody dilutions and the exposure times.

Features

- Maximal sensitivity
- Detection of low abundant proteins
- Signal stable up to 8 hours

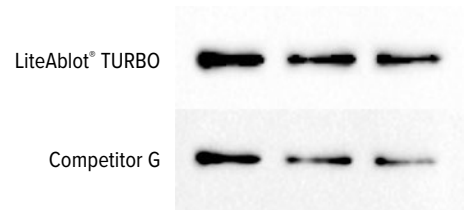

Analysis of actin expression in a serial dilution of HeLa cell lysate. Film exposure time 60 seconds.

Ordering information

Cat. Num.	Description	Size
EMP012001	LiteAblot® TURBO	50 ml + 50 ml (1000 cm ²)

Storage and Stability 1 year at 4°C

Shipping Room Temperature

Stripping

StripAblot Stripping Buffer

StripAblot is a ready-to-use buffer for the efficient stripping of Nitrocellulose and PVDF membranes probed by Western blotting procedures and detected by chemiluminescent or other non-precipitating substrates. StripAblot Buffer is a robust but gentle formulation for stripping primary and secondary antibodies from blots to enable several reprobings on the same membrane.

Features

- Ready-to-use
- Rapid protocol (5-15 minutes)
- Mercaptoethanol free

Ordering information

Cat. Num.	Description	Size
EMP100500	StripAblot	500 ml

Storage and Stability 1 year at RT or 4°C

Shipping Room Temperature

5

PLASTIC FOR
MOLECULAR
BIOLOGY

PCR, Real Time PCR and sequencing techniques require high quality plates, strips and sealings.

Euroclone PCR consumables are made for a variety of thermal cyclers, real-time PCR systems and sequencers for optimal cycling performing.

Manufacturing and Quality Control

All plastic consumables are produced under clean-room conditions in modern injection moulding facilities. Particles, bacterial cells and other contaminants are filtered from the atmosphere. Products undergo a wide range of QC inspections during and after the production process. Visual and biological tests ensure both the absence of contaminants and the integrity of quantitative PCR. In particular, the absence of nucleases (DNases and RNases), pyrogens and human genomic DNA is verified by functional QC. LAL-assay are used to test raw materials and finished products for the presence of endotoxins.

Barcoding

All skirted and semi-skirted plates are available with linear barcodes for identification and traceability. The labels are highly scratch resistant and can withstand cold storage (-80°C) and solvents, such as DMSO. Either single or double barcodes are available.

Framestar® PCR plates are covered by one or more of the following U.S. patents or their foreign counterparts, owned by Eppendorf AG: US patent nos. 7,347,977 and 6,340,589. Framestar® is a registered trademark owned by 4titude® Ltd.

FrameStar® Plates

FrameStar® PCR plates maximise thermal stability at high temperatures preventing sample loss by minimising thermal expansion during PCR. The two-component design combines the advantages of thin wall polypropylene tubes for optimum PCR results and a rigid polycarbonate skirt and deck for highest thermal stability and rigidity. In contrast to standard one-piece PCR plates, evaporation from corner positions and outer rows is minimal, allowing for downscaling of reagent volumes and cost saving.

- ✓ Two-component technology reduces thermal expansion and sample evaporation.
- ✓ Reduction of evaporation leads to improved consistency of PCR results.
- ✓ Ideal for robotics, as plate distortion is eliminated post-PCR. Well spacing and position post-PCR remain accurate, so liquid handling devices can reliably add or remove the smallest quantities from the plate.
- ✓ FrameStar® is ideal for assay miniaturisation due to no-warping rigid skirt giving better sealing properties.
- ✓ Cost saving due to downscaling of reaction volumes.
- ✓ Lack of warpage reduces variation of fluorescent signals in optical assays, such as qPCR.

Reduced evaporation and improved consistency of PCR results

Polypropylene (PP) is the optimum material for PCR tubes: it provides the most efficient heat transfer, as well as an inert surface with low binding capabilities for nucleic acids, proteins and other molecules. However, the material is not thermally stable in a plate format and expands and contracts during each PCR cycle (Fig. 1). Such thermal expansion will weaken the plate seal and leads to sample evaporation mainly from corner wells and outer rows. PCR blocks do not support PCR plates from the sides and the high temperatures from the thermal block and heated lid accelerate expansion of the plates (Fig. 2). Since thermal expansion and movement of wells in one-piece PP plates is enhanced around the edges of the plates (see Fig. 1) evaporation is the highest from the two outer rows of wells. Figure 3 illustrates the levels of sample evaporation from different areas of PP plates. Only the inner 32 wells of a one-piece 96 well plate show low levels of evaporation, so sample loss is high from the two outer rows, meaning more than 65% of the wells.

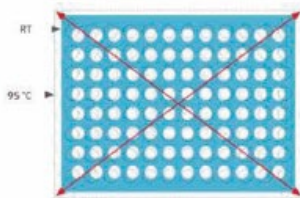

Figure 1
Standard plates with polypropylene frame expand by up to 2 mm during thermal cycling leading to movement of wells away from the plate centre. This movement is most significant in corner positions and outer rows of the plate. Sealing sheets do not expand this rate and, as a consequence, they get weakened leading to evaporation especially in corner positions and outer rows.

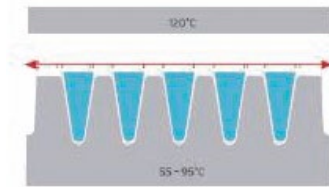

Figure 2
Side-on view of a PCR plate in a thermal cycler. The sealed plate is sandwiched between the cycler block and the heated lid but it is only partly fixed in position at the bottom of tubes, allowing the plate to expand horizontally.

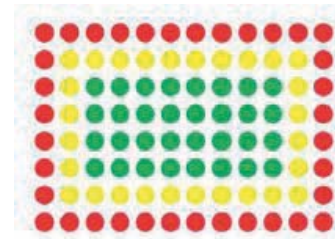

Figure 3
Evaporation from the outer rows (red) is highest, medium level evaporation occurs in the second row (yellow) and sample loss from the inner 32 wells is lowest.

FrameStar® 384 Well

Designed for high-throughput PCR, FrameStar® 384 is compatible with the majority of 384 block PCR, qPCR and sequencing instruments. The rigid two-component design eliminates warping and distortion during PCR making it ideal for use with robotic systems.

Features

- Recommended for low volume PCR
- Ideal for use with robotic systems
- Alphanumeric grid reference
- Compatible with majority of 384 block PCR, qPCR
- 30 µl recommended working capacity (55 µl max capacity)
- SBS Format

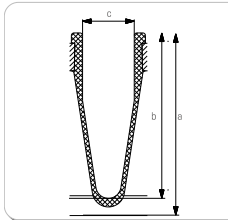
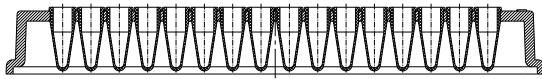

Plate width:	127,76±0,25 mm
Plate depth:	85,48±0,25 mm
Plate height (a):	10,60±0,25 mm
Well depth (b):	9,60±0,10 mm
Well diameter (c):	3,10±0,10 mm
Distance to centre of A1 from top edge:	8,99±0,25 mm
Distance to centre of A1 from left edge:	12,13±0,25 mm
Pitch (distance between A1 and A2):	4,5 mm



Ordering information*

Cat. Num.	Description	Qty/Case
ECPCR0384C	Framestar® 384 Well plate clear wells	50

* Please inquire for Roche Light Cycler® 480 Framestar® semi skirted plates

FrameStar® 96 Well Skirted Low Profile

Low profile plates have shorter wells than standard profile plates, decreasing the “dead space” between the heated lid of the thermal cycler and the sample. This eliminates condensation on the side wall of the tube, preventing reduction in PCR volume and increasing the efficiency of the reaction. Low profile products are especially recommended for use with reaction volumes below 20 µl. The rigid two-component design eliminates warping and distortion during PCR making it ideal for use with robotic systems.

Features

- Clear wells
- Raised well rims prevent cross contamination and facilitate sealing
- Suitable for cap sealing (ECPCR0751 and ECPCR0752), adhesive and thermal sealing
- Low profile
- 150 µl recommended working capacity (200 µl max capacity)
- SBS Format

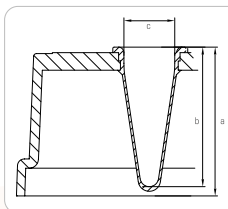
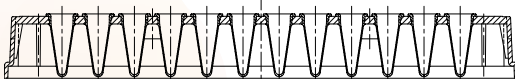

Plate width:	127,76±0,25 mm
Plate depth:	85,48±0,25 mm
Plate height (a):	16,10±0,25 mm
Well depth (b):	15,10±0,10 mm
Well diameter (c):	5,50±0,10 mm
Distance to centre of A1 from top edge:	11,24±0,25 mm
Distance to centre of A1 from left edge:	14,38±0,25 mm
Pitch (distance between A1 and A2):	9,00 mm



Ordering information

Cat. Num.	Description	Qty/Case
ECPCR0960C	Framestar® 96 well plate Skirted Low Profile	50

Framestar® 96 Semi skirted Standard Profile (cut corner A12)

Specifically designed to be directly compatible with all major thermal cyclers including all ABI instruments, this plate can be used directly in ABI 96well instruments with no adapters necessary. The rigid two-component design eliminates warping and distortion during PCR making it ideal for use with robotic systems. The semi-skirt allows for labelling or barcoding. The plate is available also with upstand.

Features

- Optimised for ABI thermal cyclers & sequencers
- Cut-off corner at A12
- Clear wells
- Raised well rims prevent cross contamination and facilitate sealing
- Suitable for cap sealing (ECPCR0751 and ECPCR0752), adhesive and thermal sealing
- 250 µl recommended working capacity (300 µl max capacity)
- Available with upstand

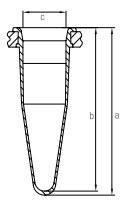
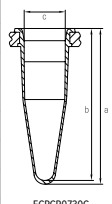

ECPCR0770C

	124,26±0,25 mm	Plate width	124,26±0,25 mm	
	83,97±0,25 mm	Plate depth	83,97±0,25 mm	
	20,70±0,25 mm	Plate height (a)	23,20±0,25 mm	
	20,20±0,10 mm	Well depth (b)	20,20±0,10 mm	
	5,46±0,10 mm	Well diameter (c)	5,46±0,10 mm	
	10,495±0,25 mm	Distance to centre of A1 from top edge	10,495±0,25 mm	
	12,63±0,25 mm	Distance to centre of A1 from left edge	12,63±0,25 mm	
	9,00mm	Pitch (distance between A1 and A2)	9,00mm	



ECPCR0730C

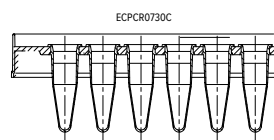
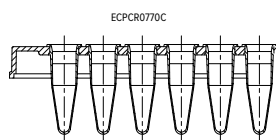

Ordering information*

Cat. Num.	Description	Qty/Case
ECPCR0770C	Framestar® 96 well plate, semi-skirted, clear wells	50
ECPCR0730C	Framestar® 96 well plate, semi-skirted with upstand, clear wells	50

* Please inquire for Roche Light Cycler® 480 Framestar® semi skirted plates

FrameStar® 96 Well Semi skirted PCR Plate

High profile, 0.2 ml polypropylene wells, polycarbonate frame, cut corner H1, working volume: <200 µl, total well capacity: 300 µl; universal semi-skirted plate designed for use on standard thermal cyclers.

Features

- The rigid FrameStar 2-component design eliminates warping and distortion during PCR, making it ideal for use with robotic systems
- The semi-skirted allows for labeling or barcoding for sample tracking
- Free from DNase, RNase, human genomic DNA, and endotoxin/pyrogen
- Ultra-smooth, uniform, thin-walled polypropylene tubes for optimum PCR and real-time (RT-qPCR) results
- <0.2 ml (200 µl) working volume, 0.3 ml (300 µl) total well capacity
- Cut corner at H1
- Rigid polycarbonate frame for added mechanical stability
- Significantly reduced thermal expansion and sample evaporation for improved consistency in PCR results
- Improved seal integrity due to thermal stability of frame
- Alphanumeric grid reference to aid well and sample identification
- Recommended for low volume PCR
- Compatible with standard multichannel pipettes
- Ideal for use with robotic systems
- Also available with white wells for optimum signal-to-noise ratio when using fluorescent based assays
- Available barcoded upon request
- Similar plate with a cut corner at A12 for use with ABI® thermal cyclers and sequencers available: FrameStar 96 Well Semi-Skirted PCR Plate, ABI® Style

Plate width:	85.48±0.25 mm
Plate length:	127.76±0.25 mm
Plate height:	20.70±0.25 mm
Well depth:	20.20±0.10 mm
Well diameter:	5.46±0.10 mm
Distance to centre of A1 from top edge:	11.24±0.25 mm
Distance to centre of A1 from left edge:	14.38±0.25 mm
Pitch (distance between A1 and A2):	9.00 mm



Ordering information

Cat. Num.	Description	Qty/Case
ECPCR0900C	Framestar® 96 Well Semi-Skirted PCR Plate	50

Framestar® Fast Plate 96 Semi skirted (recommended for ABI Fast Block Thermal cyclers)

This semi-skirted low-profile plate is recommended for ABI Fast Block thermal cyclers. Low profile plates have shorter wells than standard profile plates, decreasing the "dead space" between the heated lid of the thermal cycler and the sample. This eliminates condensation on the side wall of the tube, preventing reduction in PCR volume and increasing the efficiency of the reaction. Low profile products are especially recommended for use with reaction volumes below 20 µl. The rigid two-component design eliminates warping and distortion during PCR making it ideal for use with robotic systems. The semi-skirt allows for labelling or barcoding.

Features

- Recommended for ABI Fat Block thermal cyclers
- Clear wells
- Raised well rims prevent cross contamination and facilitate sealing
- Suitable for cap sealing (ECPCR0751 and ECPCR0752), adhesive and thermal sealing
- Low profile
- 150 µl recommended working capacity (200 µl max capacity)

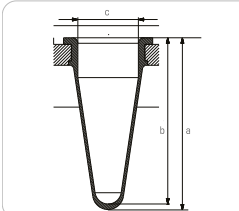

Plate width:	127,76±0,25 mm
Plate depth:	85,48±0,25 mm
Plate height (a):	16,7±0,25 mm
Well depth (b):	15,10±0,10 mm
Well diameter (c):	5,50±0,10 mm
Distance to centre of A1 from top edge:	11,24±0,25 mm
Distance to centre of A1 from left edge:	14,38±0,25 mm
Pitch (distance between A1 and A2):	9,00 mm



Ordering information

Cat. Num.	Description	Qty/Case
ECPCR0910C	FrameStar® 96 well plate semi skirted, clear wells recommended for ABI Fast cyclers	50

Standard Plates

The thin-walled tubes of Euroclone standard PCR plates maximise heat transfer and the raised rims facilitate sealing. The range consists of non-skirted, two semi-skirted and a fully skirted plate.

Primo® 96 well Plate, Non-skirted

Features

- Compatible with most thermal cyclers and sequencers
- Clear wells
- Black grid reference for easy sample identification
- Cut-off corner at H12
- Raised well rims prevent cross contamination and facilitate sealing
- Suitable for cap sealing (ECPCR0751 and ECPCR0752)
- 250 µl recommended working capacity (300 µl max capacity)

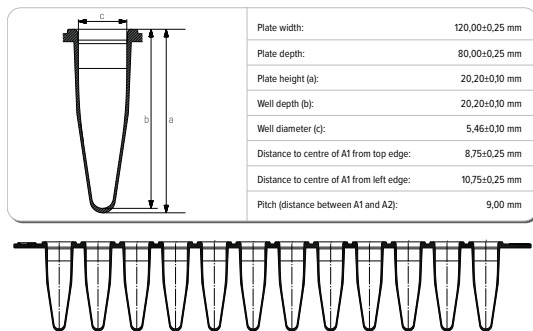

Ordering information

Cat. Num.	Description	Qty/Case
ECPCR0750C	Primo® 96 well plate non-skirted, clear wells	50

Primo® 96 well Plate, Semi-skirted

Features

- Compatible with most thermal cyclers and sequencers
- Clear wells
- Black grid reference for easy sample identification
- Cut-off corner at A12
- Raised well rims prevent cross contamination and facilitate sealing
- Suitable for cap sealing (ECPCR0751 and ECPCR0752), heat and adhesive sealing
- Suitable for bar-coding
- 250 µl recommended working capacity (300 µl max capacity)

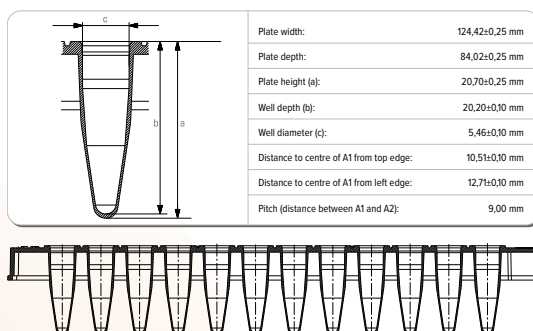

Ordering information

Cat. Num.	Description	Qty/Case
ECPCR0760	Primo® 96 well plate Semi-skirted, clear wells	50

Primo® 96 well Plate, Semi-skirted, low profile, optimized for LightCycler® 480

Features

- Optimized for use with Lightcycler® 480
- White wells, low profile
- Black grid reference for easy sample identification
- Cut-off corner at H12
- Raised well rims prevent cross contamination and facilitate sealing
- Suitable for cap sealing (ECPCR0751 and ECPCR0752), heat and adhesive sealing
- Suitable for bar-coding
- 150 µl recommended working capacity (200 µl max capacity)

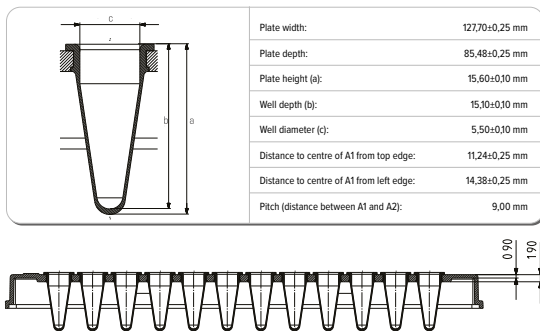

Ordering information*

Cat. Num.	Description	Qty/Case
ECPCR0955	Primo® 96 well qPCR plate Semi-skirted for LC480, white wells	50

* Please inquire for Roche Light Cycler® 480 Framestar® semi skirted plates

Primo® 96 well Plate, Skirted, low profile

Features

- Compatible with most thermal cyclers and sequencers
- Clear wells, low profile
- Black grid reference for easy sample identification
- Cut-off corner at H1
- Raised well rims prevent cross contamination and facilitate sealing
- Suitable for cap sealing (ECPCR0751 and ECPCR0752), heat and adhesive sealing
- Suitable for bar-coding
- 150 µl recommended working capacity (200 µl max capacity)

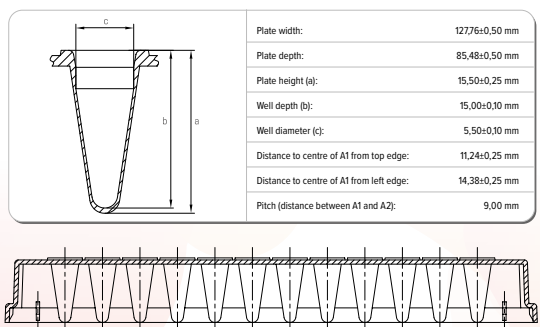

Ordering information

Cat. Num.	Description	Qty/Case
ECPCR0740C	Primo® 96 well plate Skirted, Low Profile, clear wells	50

PCR Tubes & Strips

Euroclone tubes, strips and cap strips are manufactured from virgin polypropylene in a Class 7 ISO certified cleanroom production facility. Strips are available in standard format and also with low profile tubes.

Primo® PCR tubes

Features

- Flat and domed cap designs
- Suitable for all standard 0.2 ml block thermal cyclers
- Snap-shut cap
- 0.25 ml recommended working capacity (0.3 ml max capacity)



Ordering information

Cat. Num.	Description	Qty/Case
ECPCR02F	Primo® 0.2 ml Individual PCR tubes, flat caps	1000
ECPCR02D	Primo® 0.2 ml Individual PCR tubes, domed caps	1000

Primo® Tube Strips

The tubes are individually numbered for sample recognition and available with or without caps.

Features

- Suitable for most standard thermal cyclers
- Can be cut into sections
- Available with domed or flat optical caps
- RNase, DNase, human genomic DNA free
- 250 µl recommended working capacity (300 µl max capacity)



ECPCR0208F



ECPCR0208D

Ordering information

Cat. Num.	Description	Qty/Case
ECPCR0208	Primo® 0.2 ml, 8 tubes/strip. Clear wells	125
ECPCR0208D	Primo® 0.2 ml, 8 tubes/strip. Clear wells + domed caps	125 + 125
ECPCR0208F	Primo® 0.2 ml, 8 tubes/strip. Clear wells + flat optical caps	125 + 125

Primo® Low profile Tube Strips

Primo low-profile PCR tube strips are available in clear polypropylene for standard PCR techniques. For fluorescent detection, like qPCR, low profile PCR strips are available with white well tubes which give the highest sensitivity and the highest consistency as most of the fluorescence is reflected back to the detector.

Features

- Low profile strips
- Available with either clear or white tubes
- Supplied with flat optical caps
- RNase, DNase, human genomic DNA free
- 150 µl recommended working capacity (200 µl max capacity)



ECPCR0754



ECPCR0754C

Ordering information

Cat. Num.	Description	Qty/Case
ECPCR0754C	Primo® Low profile 8 tubes/strip. Clear wells + flat optical caps	120 + 120
ECPCR0754	Primo® Low profile 8 tubes/strip. White wells + flat optical caps	120 + 120

Primo® Flat and Domed PCR Cap Strips

Features

- Easy to apply
- Large end tabs for easy removal
- Labelled for orientation
- Flat caps are optically clear for fluorescence detection (e.g. qPCR)

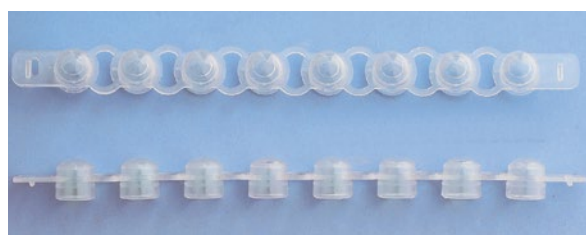

ECPCR0752



ECPCR08F



ECPCR08D

Ordering information

Cat. Num.	Description	Qty/Case
ECPCR08D	Primo® strips of 8 domed caps ONLY for PCR tube strips	125
ECPCR08F	Primo® strips of 8 flat optical caps ONLY for PCR tube strips	125
ECPCR0752	Primo® strips of 8 domed caps for PCR plates	300
ECPCR0751	Primo® strips of 8 flat optical caps for PCR plates	300
ECPCR0788	Primo® strips of 12 flat optical caps for PCR plates	200

Adhesive Sealing Films & Foils

Euroclone offers a wide range of adhesive sealing materials processed under strictly controlled environmental conditions and certified free from DNase, RNase and human genomic DNA.

Primo[®] Adhesive PCR Seals

A strong polyester transparent adhesive seal recommended for PCR but it can also be used for qPCR and other optical applications. This seal enables a high seal integrity and efficiently prevents sample evaporation. The seal can be easily peeled from the plate.

Features

- Application: PCR and qPCR
- Peelable
- Adhesive free end tabs for ease of application and removal
- Seal integrity range: -20°C to 110°C
- Non-sterile



Ordering information

Cat. Num.	Description	Qty/Case	Dimensions
ECPCR0500	Primo [®] Transparent Adhesive PCR Seal	100 sheets	135 x 80 mm

Primo[®] PCR Aluminium Foil Seal

This aluminium foil seal has a strong acrylic adhesive which guarantees a high integrity sealing. It is recommended for PCR and other high temperature applications. It can be pierced and peeled.

Features

- Application: PCR
- Peelable
- Pierceable
- Perforated end tabs for ease of application and removal
- Seal integrity range: -40°C to 120°C
- Non-sterile



Ordering information

Cat. Num.	Description	Qty/Case	Dimensions
ECPCR0550	Primo [®] Aluminium Foil Adhesive Seal	100 sheets	130 x 80 mm

Primo® qPCR Seal

This optically clear seal has been specifically developed for optical applications, especially qPCR. It is non-tacky to skin and gloves enabling ease of handling and application. This is a pressure activated seal: the polyester film has adhesive held within capsules on the underside and pressure must be applied to the top-side around the raised-well rims to activate the adhesive.

Features

- Application: qPCR
- No adhesive to come into contact with samples
- Non-sterile
- Non-pierceable
- Peelable
- Seal integrity range: -80°C to 110°C



Ordering information

Cat. Num.	Description	Qty/Case	Dimensions
ECPCR0560	Primo® qPCR Adhesive Seal	100 sheets	140 x 77 mm

Primo® Microplate Adhesive Transparent Seal

This transparent polyester-based film has a low strength adhesive and it is removable without residue on the plate; it is useful for short term storage and as a cover for applications such as centrifugation. End tabs allow for easy application and removal.

Features

- Non-pierceable
- Peelable
- Seal integrity range: -20°C to 80°C
- Free from DNase, RNase, and human genomic DNA



Ordering information

Cat. Num.	Description	Qty/Case	Dimensions
ECPCR0510	Primo® Microplate Adhesive Transparent Seal	100 sheets	130 x 80 mm

Heat Sealing Films & Foils

Heat sealing is the gold standard method for plate sealing. It minimises sample loss and maximises sample security for PCR, qPCR, storage and other applications. The sealing performance of heat seals is superior to cap, mat and adhesive sealing with clear reductions in sample loss and cross contamination.

The optimized sealing performance allows use of smaller reaction volumes leading to reagent savings.

Euroclone offers a choice of heat seals in both roll and sheet format. Different seals can be chosen to optimize the use depending on plate material, desired permeability or resistance, ability to peel or pierce the seal material and visualisation through the material. All seals are certified free from nucleases and human genomic DNA contamination.

Primo[®] Transparent seal I

This clear seal is recommended for PCR, qPCR and other optical applications.

Features

- Application: PCR, qPCR, short term compound storage
- Non-pierceable
- Peelable
- Non-sterile
- Seal integrity range: -80°C to 80°C (110°C with pressurized heated PCR lid)

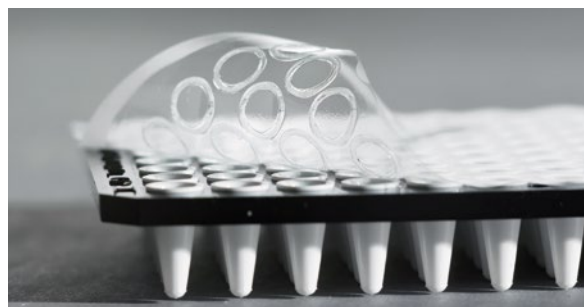

Ordering information

Cat. Num.	Description	Qty/Case	Dimensions
ECPCR0541	Primo [®] Transparent Seal I	100 sheets	125 x 80 mm
ECPCR0540	Primo [®] Transparent Seal I	1 roll*	500 x 78 mm Approx 4200 seals
ECPCR0542	Primo [®] Transparent Seal I	1 roll**	350 x 115 mm Approx 4400 seals

*Compatible with Thermo Fisher ALPS 300[™]/ALPS 3000[™]/KBiosystem Wasp[™]/KBioscience FlexiSeal and Cube

**Compatible with Agilent (Velocity 11) Plateloc[®]

Note: Rolls are also available on 150 mm for REMP sealers. Please enquire.

Primo[®] Transparent seal II

This clear seal is recommended for PCR, qPCR and other optical applications. This film forms a permanent bond to polypropylene plates that cannot be peeled, and it is very difficult to pierce. It has a very good solvent resistance.

Features

- Application: PCR, qPCR, storage of hazardous material
- Non-pierceable
- Non-peelable
- Non-sterile
- Seal integrity range: -80°C to 110°C

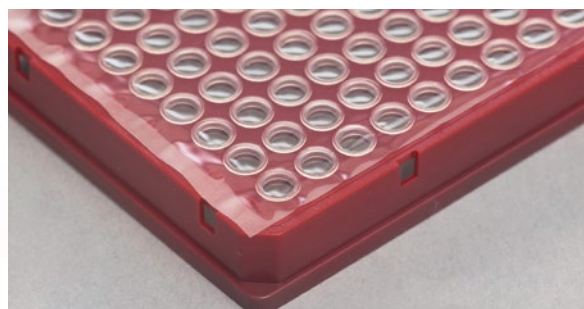

Ordering information

Cat. Num.	Description	Qty/Case	Dimensions
ECPCR0575	Primo [®] Transparent Seal II	100 sheets	125 x 78 mm

Primo® Transparent Seal for ABI 3730 Sequencer

This thin polyester heat sealing film is easily pierceable with autosampler needles/ABI® 3730; it is suitable for PCR, qPCR and optical applications. It comes as perforated roll, for easy removal of sheets.

Features

- Permanent seal
- Moderate solvent resistance
- Optically clear
- Free from DNase, RNase, human genomic DNA, and endotoxin/pyrogen
- Seal integrity range: -20°C to 80°C (or 110°C when used with pressurized heated PCR lid)

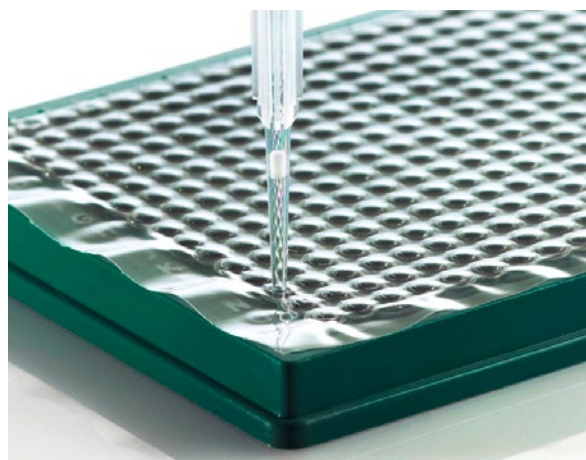

Ordering information

Cat. Num.	Description	Qty/Case	Dimensions
ECPCR0581	Primo® Transparent Seal for ABI 3730 Sequencer (heat sealing)	Approx 1000 sheets on perforated roll	125 x 78 mm

Primo® Peelable seal

This is a laminate peelable seal that can be easily removed from polypropylene plates but not from polyethylene plates.

Features

- Application: PCR, Low temperature, compound storage, short term room temperature compound storage
- Non-Pierceable
- Peelable
- Non-sterile
- Seal integrity range: -80°C to 90°C (up to 110°C with pressurized heated PCR lid)

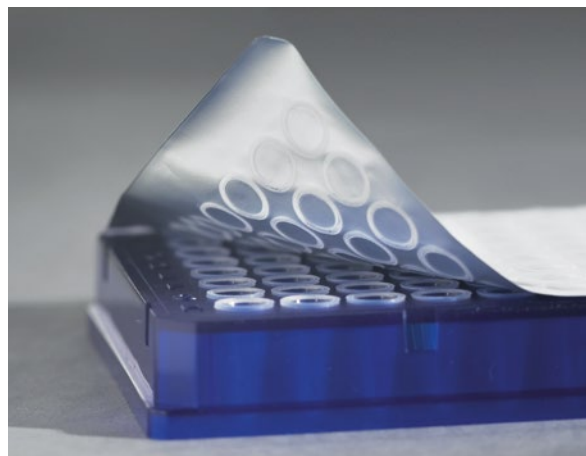

Ordering information

Cat. Num.	Description	Qty/Case	Dimensions
ECPCR0521	Primo® Peelable Seal	100 sheets	125 x 78 mm
ECPCR0520	Primo® Peelable Seal	1 roll*	610 x 78 mm Approx 5000 seals
ECPCR0522	Primo® Peelable Seal	1 roll**	500 x 115 mm Approx 6250 seals

*Compatible with Thermo Fisher ALPS 300™/ALPS 3000™/KBiosystem Wasp™/KBioscience FlexiSeal and Cube

**Compatible with Agilent (Velocity 11) Plateloc®

Note: Rolls are also available on 150 mm for REMP sealers. Please enquire.

Primo® DMSO resistant Peelable seal

This is a laminate peelable seal that can be easily removed from polypropylene plates but not from polyethylene plates.

Features

- Application: PCR, Low and room temperature compound storage
- Resistant to 100% DMSO (at room temperature for 12 months with no deterioration of the seal quality)
- Non-pierceable
- Peelable
- Non-sterile
- Seal integrity range: -80°C to 40°C



Ordering information

Cat. Num.	Description	Qty/Case	Dimensions
ECPCR0587	Primo® Peelable Seal DMSO resistant	100 sheets on perforated roll	125 x 78 mm
ECPCR0585	Primo® Peelable Seal DMSO resistant	1 roll*	500 x 78 mm Approx 4200 seals
ECPCR0586	Primo® Peelable Seal DMSO resistant	1 roll**	500 x 115 mm Approx 6200 seals

*Compatible with Thermo Fisher ALPS 300™/ALPS 3000™/KBiosystem Wasp™/KBioscience FlexiSeal and Cube

**Compatible with Agilent (Velocity 11) Plateloc®

Note: Rolls are also available on 150 mm for REMP sealers. Please enquire.

Primo® Pierceable Seal

This is a foil-based seal that can be easily pierced from polypropylene or polystyrene plates. It has a very good solvent resistance. A blue colour print identifies the non-sealing surface for ease of application. This seal remains intact to very high temperatures.

Features

- Application: PCR, Low and room temperature compound storage
- Resistant to 100% DMSO
- Pierceable
- Non-sterile
- Seal integrity range: -20°C to 120°C



Ordering information

Cat. Num.	Description	Qty/Case	Dimensions
ECPCR0531	Primo® Pierceable Seal	100 sheets	125 x 78 mm
ECPCR0530	Primo® Pierceable Seal	1 roll*	610 x 78 mm Approx 5000 seals
ECPCR0532	Primo® Pierceable Seal	1 roll**	500 x 115 mm Approx 6200 seals

*Compatible with Thermo Fisher ALPS 300™/ALPS 3000™/KBiosystem Wasp™/KBioscience FlexiSeal and Cube

**Compatible with Agilent (Velocity 11) Plateloc®

Note: Rolls are also available on 150 mm for REMP sealers. Please enquire

Primo® Foil Peelable and Pierceable seal

This aluminium foil seal seals both to polypropylene and polystyrene and can be pierced and peeled. It has a very good solvent resistance. A red colour print identifies the non-sealing surface for ease of application.

Features

- Application: PCR, low and room temperature compound storage
- Resistant to 100% DMSO
- Pierceable
- Peelable
- Non-sterile
- Seal integrity range: -20°C to 110°C

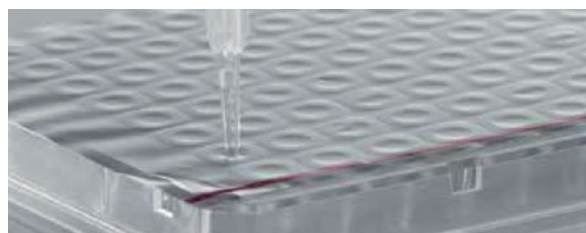

Ordering information

Cat. Num.	Description	Qty/Case	Dimensions
ECPCR0536	Primo® Foil Seal	100 sheets	125 x 78 mm
ECPCR0535	Primo® Foil Seal	1 roll*	610 x 78 mm Approx 5000 seals

*Compatible with Thermo Fisher ALPS 300™/ALPS 3000™/KBiosystem Wasp™/KBioscience FlexiSeal and Cube

Note: Rolls are also available on 150 mm for REMP sealers. Please enquire.

Primo® Thermal Bond Seal

This a very strong polypropylene laminate thermal seal that can be peeled. It has a very good solvent resistance.

Features

- Application: PCR, low and room temperature compound storage
- Resistant to 100% DMSO
- Non-Pierceable
- Peelable
- Non-sterile
- Seal integrity range: -200°C to 110°C

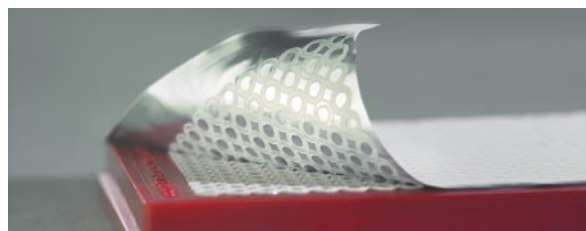

Ordering information

Cat. Num.	Description	Qty/Case	Dimensions
ECPCR0591	Primo® Thermal Bond Seal	100 sheets	125 x 78 mm
ECPCR0590	Primo® Thermal Bond Seal	1 roll*	500 x 78 mm Approx 4200 seals

*Compatible with Thermo Fisher ALPS 300™/ALPS 3000™/KBiosystem Wasp™/KBioscience FlexiSeal and Cube

Primo® Air-O-seal, Hydrophobic Gas Permeable Adhesive Seal

Gas permeable adhesive seal, peelable; suitable for cell culture.

Features

- Cell Culture Adhesive Seal is a gas permeable adhesive seal which seals assay and tissue culture plates, microplates and storage plates
- Cell Culture Adhesive Seal prevents evaporation and contamination whilst enabling cells to breathe. It is made of a nonwoven fiber with an acrylate adhesive layer for effective sealing
- The seal has a low moisture transfer rate and a porosity enabling gas exchange
- Due to its paper-based material it should not be used in wet conditions
- Suitable for cell culture and enables long term culture with significantly reduced evaporation
- Peelable
- Seal integrity range: -20°C to 40°C
- Gas permeability rate: 8,900 m³/m²/day
- Moisture vapor transmission rate (very low): 4,200 g/m²/day
- Air porosity: 10 sec/100 cc/in²
- RNase/DNase free
- Application: bacterial and eukaryotic cell culture



Ordering information

Cat. Num.	Description	Qty/Case	Dimensions
ECPCR0517	Primo® Air-O-seal, Hydrophobic Gas Permeable Adhesive Seal	100 sheets	135 x 80 mm

Adhesive Seal Roller and Applicator

Adhesive Seal Roller ensures that pressure is applied across the adhesive seal for complete and secure application to your plate, across every well. The handle of the Adhesive Seal Roller is made of a durable plastic, with a semi-hard padded rolling wheel. The straight rigid sides of the small-sized Adhesive Seal Applicator allow for even pressure application.



Ordering information

Cat. Num.	Description	Qty/Case
ECPCR0502	Primo® Roller for adhesive seals	1 pz

RELATED PRODUCTS

PCR	pag. 14
qPCR	pag. 15
RT-PCR	pag. 16
Agaroses	pag. 22 - 24
DNA ladders	pag. 25, 26

6

PRIMO[®]
MECHANICAL
PIPETTES AND
PRIMO[®] TIPS

Primo® Mechanical pipettes

Primo® Mechanical pipettes

High quality devices to guarantee maximum precision and reproducibility of measurement.

- ✓ Fully autoclavable
- ✓ UV resistant
- ✓ Ultra low pipetting forces
- ✓ Easy recalibration system
- ✓ 3 years warranty

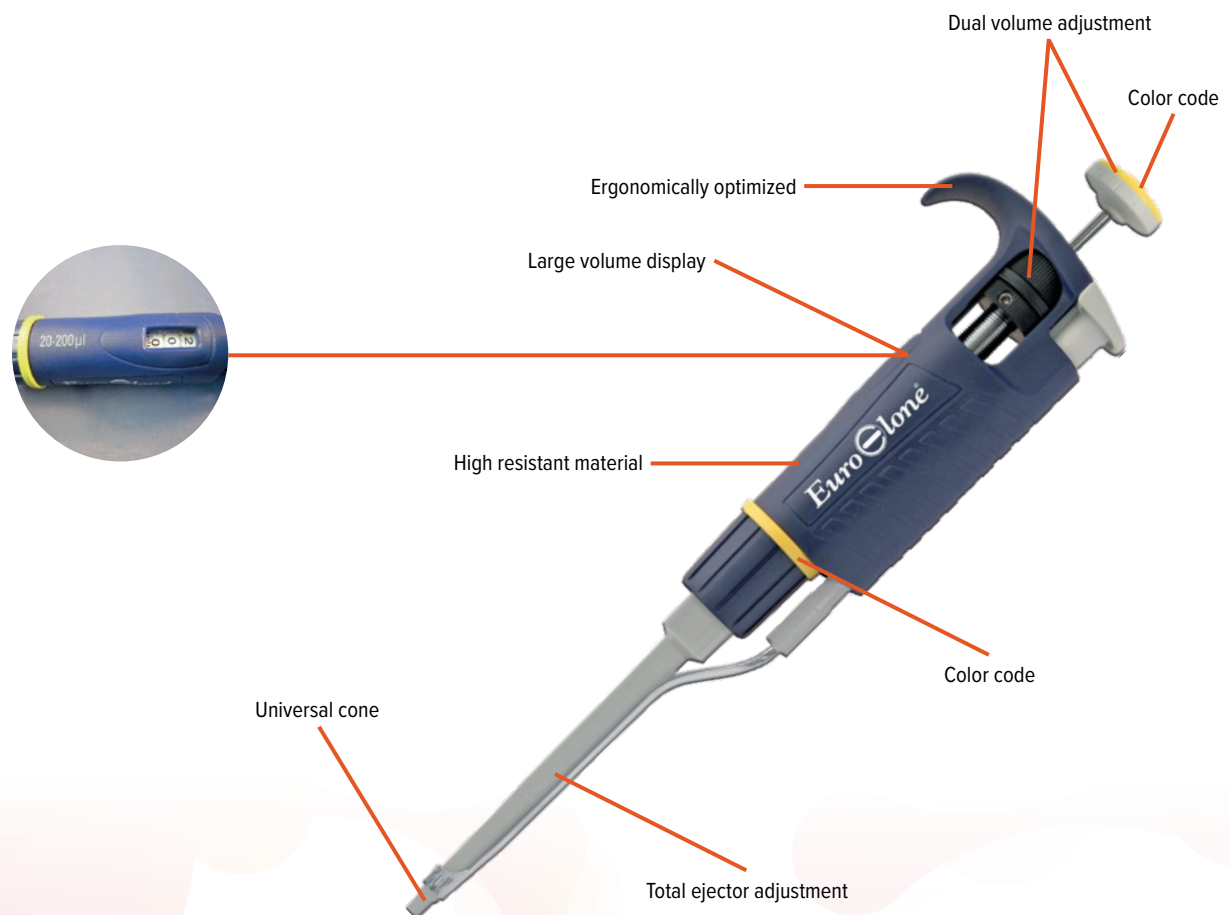

Ordering Information

	Cat.No	Description	Volume [µl]	Accuracy %*	Precision %*
Single Channel	ECP10002	Single channel mechanical pipette Primo® 0.2 - 2 µl	0.2 1.0 Max 2.0	± 12.0 ± 2.7 ± 1.5	± 2.8 ± 0.6 ± 0.4
	ECP10010	Single channel mechanical pipette Primo® 0.5 - 10 µl	Min 0.5 5.0 Max 10.0	± 4.0 ± 1.0 ± 0.5	± 2.8 ± 0.6 ± 0.4
	ECP10020	Single channel mechanical pipette Primo® 2 - 20 µl	Min 2 10 Max 20	± 3.0 ± 1.0 ± 0.8	± 1.5 ± 0.5 ± 0.3
	ECP10100	Single channel mechanical pipette Primo® 10 - 100 µl	Min 10 50 Max 100	± 1.6 ± 0.8 ± 0.8	± 0.80 ± 0.24 ± 0.20
	ECP10200	Single channel mechanical pipette Primo® 20 - 200 µl	Min 20 100 Max 200	± 1.2 ± 0.8 ± 0.6	± 0.60 ± 0.25 ± 0.20
	ECP11000	Single channel mechanical pipette Primo® 100 - 1000 µl	Min 100 500 Max 1000	± 1.6 ± 0.7 ± 0.6	± 0.40 ± 0.20 ± 0.15
Multichannel	ECP80010 (+)	Mechanical pipette 8 Channels Primo® 0.5 - 10 µl	Min 0.5 5 Max 10	±10.0 ±4.0 ±2.0	± 8.0 ± 2.0 ± 1.2
	ECP12010 (#)	Mechanical pipette 12 Channels Primo® 0.5 - 10 µl			
	ECP80050 (+)	Mechanical pipette 8 Channels Primo® 5 - 50 µl	Min 5 25 Max 50	±4.0 ±3.0 ±1.6	± 2.5 ± 1.2 ± 0.6
	ECP12050 (#)	Mechanical pipette 12 Channels Primo® 5 - 50 µl			
	ECP80200 (+)	Mechanical pipette 8 Channels Primo® 20 - 200 µl	Min 20 100 Max 200	±3.0 ±1.5 ±1.0	± 3.0 ± 1.5 ± 1.0
	ECP12200 (#)	Mechanical pipette 12 Channels Primo® 20 - 200 µl			
	ECP80300 (+)	Mechanical pipette 8 Channels Primo® 50 - 300 µl	Min 50 150 Max 300	±1.6 ±1.2 ±1.0	± 1.5 ± 1.0 ± 0.6
	ECP12300 (#)	Mechanical pipette 12 Channels Primo® 50 - 300 µl			

(*) The accuracy and precision (repeatability) of liquid volume depend on the quality of tips used. The values for accuracy and precision given in the table above were obtained using Euroclone tips

(+) 8 Channel

(#) 12 Channel

To choose the correct tip, please see compatibility chart pag 32

Primo® Tips

Primo® Tips are made of transparent high quality virgin polypropylene. Tips fit with most of the common mechanical and Electronic pipettes in the market. See the pipette tips compatibility chart on pag 32.

Common Features:

- Crystal clear quality
- Low retention
- Accurate graduation marks
- Packed in extra-rigid autoclavable racks
- Sterilized by gamma irradiation, according to ISO 11137 recommendations in force, with SAL> 10⁻⁶ (if applicable)
- Non-pyrogenic, tested on LAL according to FDA guidelines for medical devices. Maximum acceptance level is less than 0.5 EU/ml.
- DNase and RNase free
- Non-cytotoxic tested according to USP and ISO 10993 standards in force.

Primo® PREMIERE Bulk Tips non filtered

PREMIERE Bulk tips are supplied in self-supporting, self-sealing plastic bags, which allow convenient use and storage. The tips can be used directly from the bag or can be manually refilled into the empty PREMIERE filter-tip racks.

Bulk pipette tips are the ideal choice for cost-conscious customers. The tips are manufactured under the same stringent conditions as PREMIERE tips and are certified according to RNase, DNase, DNA and pyrogen-free standards. They offer universal compatibility with all major pipette brands on the market. Please check the pipette tips compatibility chart on pag 70.

Ordering Information

Cat. No.	Description	Qty/case
ECTD10010	Primo® PREMIER tips 0,1-10 µl, clear, bag	1000
ECTD10012	Primo® PREMIER tips 0,2-10 µl, Long, Extra narrow, clear bag	1000
ECTD10200	Primo® PREMIER tips 2-200 µl, clear, bag	1000
ECTD10300	Primo® PREMIER tips 2-300 µl, clear, bag	1000
ECTD11000	Primo® PREMIER tips 100-1000 µl, clear, bag	500
ECTD11250	Primo® PREMIER tips 100-1250 µl, XL, clear, bag	500

Primo® ECO Racked Tips non filtered

The manufacturing process makes the internal surface of the tip extremely homogeneous, increasing its hydrophobicity and thus significantly reducing sample loss and providing greater reproducibility when working with critical reagents.

ECO Racked Tips are available in Sterile and non-sterile version.

The practical 96x20 rack packaging allows to reduce the volume of the boxes, saving space and the consequent disposal of packaging materials.

ECO Filter Tips fit the common mechanical and electronic pipettors in the market. See the pipette tips compatibility chart on pag 70.



Ordering Information

Cat. No.	Description	Qty/case
ETT0010RN	Primo® ECO tips low retention 10 µl racked non sterile	96x20
ETT0200RN	Primo® ECO tips low retention 200 µl racked non sterile	96x20
ETT1000RN	Primo® ECO tips low retention 1000 µl racked non sterile	96x20
ETT0010RS	Primo® ECO tips low retention 10 µl racked sterile	96x20
ETT0200RS	Primo® ECO tips low retention 200 µl racked sterile	96x20
ETT1000RS	Primo® ECO tips low retention 1000 µl racked sterile	96x20

Primo® PREMIER Filter Tips

Premier Filter Tips are the ideal choice for all applications that require maximum precision.

Low retention pipette tips have an ultra-smooth inner surface, which increases the hydrophobicity of the surface to minimize sample binding. This feature is achieved thanks to the resin (virgin polypropylene of high purity) and the high quality molds used in the production process.

Premier Filter Tips are manufactured in a clean room facility. Premier filter tips are certified free of RNase, DNase and pyrogen. This makes them particularly suitable for particularly sensitive samples and critical applications in the field of molecular biology.

Premier Filter Tips are universally compatible with most brands of pipettes on the market. See the pipette tips compatibility chart on pag 70.



Ordering Information

Cat. No.	Description	Qty/case
ECTD00010	Primo® PREMIER filter tips 0,1-10 µl, Sterile Low retention, racked	96x10
ECTD00012	Primo® PREMIER filter tips 0,2-10 µl, Long, Extra narrow, Sterile, Low retention, racked	96x10
ECTD00020	Primo® PREMIER filter tips 2-20 µl, Sterile, Low retention, racked	96x10
ECTD00100	Primo® PREMIER filter tips 2-100 µl, Sterile, Low retention, racked	96x10
ECTD00200	Primo® PREMIER filter tips 2-200 µl, Sterile, Low retention, racked	96x10
ECTD00300	Primo® PREMIER filter tips 2-300 µl, Sterile, Low retention, racked	96x10

Primo® ECO Filter Tips

The manufacturing process makes the internal surface of the tip extremely homogeneous, increasing its hydrophobicity and thus significantly reducing sample loss and providing greater reproducibility when working with critical reagents.

The hydrophobic filter mounted in the tips prevents cross contamination between different samples in applications such as cell and molecular biology. The practical 96x20 rack packaging allows to reduce the volume of the boxes, saving space and the consequent disposal of packaging materials. ECO Filter Tips fit the common mechanical and electronic pipettors in the market. See the pipette tips compatibility chart on pag 70.

Ordering Information

Cat. No.	Description	Qty/case
ETT0010FT	Primo® ECOTIP filtered, sterile, 10 µl, low retention, racked	96x20
ETT0020FT	Primo® ECOTIP filtered, sterile, 20 µl, low retention, racked	96x20
ETT0100FT	Primo® ECOTIP filtered, sterile, 100 µl, low retention, racked	96x20
ETT0200FT	Primo® ECOTIP filtered, sterile, 2-200 µl, low retention, racked	96x20
ETT1000FT	Primo® ECOTIP filtered, sterile, 100-1000 µl, low retention, racked	96x20



7

SERVICES

Services

Our Services have been developed to support the everyday life of Researcher and to offer flexible solutions responding to customers' needs.

Stockroom

A Stockroom* is a storage place for our products created directly at the customer's site: all researchers have access to Euroclone's kits and reagents directly from their Institute (University or Hospital). The Researcher is free to take an item from the Stockroom whenever needed; every month the customer will get a summary of the pickings and the corresponding order will be processed.

The stocks are automatically reinstated by Euroclone based on customer's consumption.

The list of products available in stock is completely customizable and can be modified at any time.

Virtual Stockroom

The Virtual Stockroom service* allows customers to place orders online through a reserved portal; it is a special system which makes purchase simple and still compliant with MEPA requirements (Mercato Elettronico della Pubblica Amministrazione). Virtual StockRoom's customers not only have dedicated annual supply conditions and offers, but also can take advantage of temporary promotions, both for Euroclone branded products and for distributed product lines.

The ordering procedure is customizable according to the customer's needs.

**Stockroom and Virtual Stockroom are services available only in Italy.*

Scheduled annual deliveries

The annual order with the scheduling of deliveries, on agreed dates, allows to avoid problems and delays and always be provided with the right supply of products.

Technical Sales Specialist

Euroclone technical specialists are available providing a wide range of services to support all needs (both for Euroclone products and for distributed products) thus offering important direct support on the Italian territory.

- ✓ Pre and post sales consultancy
- ✓ Instrument installation
- ✓ Training using instruments
- ✓ Technical and practical demonstrations
- ✓ Technical assistance
- ✓ Troubleshooting
- ✓ Scientific support

Technical Sales Assistant

The technical assistant takes care of all the post-sales operational needs.

- ✓ Provides technical information
- ✓ Handles requests with the supplier technical service
- ✓ Technical support on the consumable

Contact: tsa@euroclone.it / 800-315911

Quality

The medical devices we market and the in vitro diagnostic devices used in cytogenetics comply with European regulations 2017/745 e 2017/746. Euroclone sells its own brand products in Europe and in non-European countries in compliance with international regulations, including the DUAL USE regulation.

Euroclone is a supplier of companies in the Biotech area – Pharma that work in GMP, and guarantees products FFM (For Further Manufacture) in compliance with specific Quality Technical Agreement defined with individual customers.

Certifications

ISO 9001, ISO 13485 e ISO 14001.

ISO 9001 and ISO 13485 certify that our company, from the point of view of design, development, technical assistance and marketing for products for life sciences, medical devices and in vitro diagnostic devices, complies with the regulations currently in force.

ISO 14001 certifies that Euroclone works in full respect of the environment and its actions are characterized by a strong ecological footprint.

TECHNICAL
APPENDIX

Technical Appendix

Plate compatibility table

Standard Thermal Cyclers																																							
	Veriti, Proflex, Simplicamp	GeneAmp® 2700/2700/9600/9700	GeneAmp® 9800 FAST, Veriti FAST	GeneAmp 9700, Veriti, Proflex, Multiblock system	Surecycler 8800	SureCycler 8800	Robocycler Gradient	TRIO, Tpersonal, T3 Thermocycler	Flexicyler2, T1 Thermocycler, Tgradient, Tone, Tadvanced, Tprofessional (Standard/Basic) GradientXL	Trobot 96, SpeedCycler 2 (SP, SPR)	Flexicyler2, T1 Thermocycler, Tadvanced, Tprofessional, Trobot 96	GeneQ	Gene Touch 96/Life ECO	Gene Touch 384	Genecycler	C1000 Touch, S1000	iCycler™, iMyCycler™, T100	C1000 Touch, S1000	Mini Gradient	Personal	PTC100™/200™/220™/221™/225™/240™	PTC200™/220™/221™/225™/240™	(Qiagen) Palm Cycler	(Qiagen) Palm Cycler 384	MasterCycler® ep/ep gradient/Pro/Pro S/nexus/nexus gradient/nexus SX/nexus 6Sx1	MasterCycler® nexus X2/GX2/GX2e/X2e	MasterCycler® ep 384/Pro 384	peqSTAR XS, peqSTAR 2X	peqSTAR 96X	peqSTAR 384X	Labcyler	Labcyler							
	96 well standard block	96 well FAST block	384 well block	96 well block	384 well block	96 well block	Strips only	96 well block	384 well block	Strips only	96 well block	384 well block	Strips only	96 well block	384 well block	96 well block	384 well block	Strips only	96 well block	384 well block	96 well block	384 well block	96 well block	384 well block	96 well block	384 well block	Strips only	96 well block	384 well block	96 well block	384 well block	96 well block	384 well block						
	ABI Life Technologies Thermo Fisher Scientific			Agilent Stratagene				Analytik Jena Bionetra			Boehr Technologies			BioRad		BioRad MJ Research			Corbett Research		Eppendorf		PEQLAB VWR		Sensquest														
FrameStar® Plates																																							
ECPCR0384C 384 well			X	X					X		X				X					X	X																		
ECPCR0960C 96 well unskirted						X		X	X						X					X								X					X						
ECPCR0770C 96 well semi-skirted	X	X						X	X		X				X	X				X								X					X						
ECPCR0730C 96 well semi skirted with upstand	X	X																																X					
ECPCR0910C 96 well semiskirted			X																																X				
ECPCR0900C FrameStar® 96 semi skirted PCR Plate (cut corner bottom left), clear frame						X		X	X			X			X	X				X	X		X								X			X					
Standard Plates																																							
ECPCR0750C 96 well unskirted	X	X		X	X		X	X			X				X	X				X	X							X			X								
ECPCR0760 96 well semiskirted	X	X						X	X		X				X	X				X	X							X			X								
ECPCR0740C 96 well skirted					X			X							X						X									X					X				
ECPCR0955 96 well semiskirted for LC Roche. White wells																																							
Tubes and Strips																																							
ECPCR0208D/ ECPCR0208F 8 tube-strips	X	X		X			X	X	X		X	X		X	X	X			X	X		X					X	X		X	X		X						
ECPCR0754C/ ECPCR0754 8 tube-strips low profile					X			X							X						X						X	X		X	X		X						

										qPCR Cyclers										Sequencers																					
Dice touch, Gradient	96 well block	Takara																																							
3Prime, 3PrimeG, 3PrimeX	Strips only																																								
Prime, PrimeG, Prime Elite, Prime Elite Satellite																																									
PCRMmax Alpha cycler 1/2/4	96 well block	Techn																																							
TC412, TC512, Genius, Genius Quad, Touchgene Gradient, Flexgene																																									
Prime, PrimeG, Prime Elite, Prime Elite Satellite																																									
PCRMmax Alpha cycler 1/2/4	384 well block																																								
TC412, TC512, Genius, Genius Quad, Flexgene																																									
7000i/7300i/7500i/7900i/9000i HT																																									
QuantStudio™ 3/5/6/7/12k, ViiA™7™	96 well standard block																																								
StepOne																																									
StepOnePlus™																																									
7500 FAST, 7900 HT FAST																																									
QuantStudio™ 3/5/6/7/12k, ViiA™7™	96 well FAST block	ABI Life Technologies Thermo Fisher Scientific																																							
QuantStudio 516/712k, ViiA™7™, 7900 HT FAST	384 well block																																								
AriaMx																																									
Mx3000P™, Mx3005P™	96 well block	Agilent Stratagene																																							
Mx4000™																																									
qTOWER3 Gtouch, Topical	96 well block	Analytik Jena Biomatra																																							
qTOWER3 84/84G	384 well block																																								
CFX96 Touch, CFX96X Touch Deep Well, CFX connect	96 well block	BioRad																																							
MyiQ™, iCycler™ IQ4/iQ 5																																									
CFX384 Touch	384 well block																																								
MiniOpticon	Strips only																																								
Chromo4™	96 well block	BioRad MJ Research																																							
Opticon2™																																									
Rotor-Gene series	Strips only	Corbett Research																																							
MasterCycler® ep realplex	96 well block	Eppendorf																																							
LC96, LC480	96 well block																																								
LC480	384 well block	Roche																																							
Nano	Strips Only																																								
Quantica	96 well block	Techn																																							
3100, 3130XL, 3500, 3500XL, 3730, 3730XL	96 well block																																								
3100, 3130XL, 3500, 3500XL, 3730, 3730XL	384 well block																																								
MegaBACE™ 500, MegaBACE™ 1000 mark 2	96 well block																																								
MegaBACE™ 4000	384 well block	GE Healthcare Amersham																																							

Adhesive Seal Films and Foils

Description	Primo® Adhesive PCR seal	Primo® PCR Aluminium foil seal
Cat.	ECPCR0500	ECPCR0550
Application	PCR	<ul style="list-style-type: none"> • PCR & sample storage • Incubations
Special Properties	Good optical clarity	Irregular tearing when pierced prevents formation of vacuum
Min Temp	-20°C	-40°C
Max Temp	110°C	120°C
Sterile	No	No
Pierceable	No	Yes
Peelable	Yes	Yes
RNase/DNase free	Yes	Yes
Dimensions	135 x 80 mm	130 x 80 mm

Heat Sealing Films & Foils

Description	Primo® Transparent Seal I	Primo® Transparent Seal II	Primo® Transparent Seal For ABI 3730 Sequencer	Primo® Peelable seal
Roll 78 mm width (1) (length)	ECPCR0540 (500 mm)	-	-	ECPCR0520 (610 mm)
Roll 115 mm width (2) (length)	ECPCR0542 (350 mm)	-	-	ECPCR0522 (500 mm)
Sheets (dimensions)	ECPCR0541 (125 x 80 mm)	ECPCR0575 (125 x 80 mm)	ECPCR0581 (+) (125 x 78 mm)	ECPCR0521 (125 x 78 mm)
Application	qPCR, short term compound storage	PCR (esp. water bath cyclers), qPCR, Storage & disposal of hazardous materials	qPCR and for use with ABI 3730 Sequencer	Low temperature, compound storage, short term room temperature compound storage (<5 days), PCR
Special Properties	Good optical clarity. Moderate solvent resistance	Good optical clarity & resistant to DMSO	Good optical clarity, some solvent resistance	Can be peeled directly from -80°C freezer. Moderate resistance to solvents at room temperature
Min Temp	-80°C	-80°C	-20°C	-80°C
Max Temp	80°C (or 110°C with pressurised heated PCR lid)	110°C	80°C (or 110°C with pressurised heated PCR lid)	90°C (or 110°C with pressurised heated PCR lid)
Sterile	No (*)	No (*)	No (*)	No (*)
Pierceable	No	No	Yes	No
Peelable	Yes	No	No	Yes
RNase/DNase free	Yes	Yes	Yes	Yes
Material	Laminate	Polymer	Polymer	Laminate
Seals to	PP, PE, PS, PC, COC	PP	PP, PE, PS, COC	PP, COC

* Available as sterile on request

(+) 1000 sheets supplied on a perforated roll

(#) 100 sheets supplied on a perforated roll

(1) Compatible with Thermo Fisher ALPSs 300™/ALPS3000™/KBiosystems Chameleon™/KBioscience FlexiSeal & Remp/Tecan Plate Sealer

(2) Compatible with Agilent (Velocity 11) PlateLoc®

PP: Polypropylene/PS: Polystyrene/COC: Cyclic Olefin Copolymer/ PE: Polythene/PC: Polycarbonate

NB: Rolls are also available on 150 mm core for Remp/Tecan sealers. Please enquire.

Primo® qPCR seal	Primo® microplate seal	Primo® Air-O-seal, Hydrophobic Gas Permeable Adhesive Seal
ECPCR0560	ECPCR0510	ECPCR0517
<ul style="list-style-type: none"> • qPCR & other fluorescent applications • Imaging techniques incl., crystallisation • Plate readers, microscopy 	Aqueous sample storage	Bacterial or cell culture
Good optical clarity	Medium strength transparent seal	<ul style="list-style-type: none"> • Very low moisture transfer rate • Suitable for bacterial or cell culture • Air porosity: 10 sec/100 cc/in²
-80°C	-20°C	-20°C
110°C	80°C	80°C
No	No	Yes
No	No	No
Yes	Yes	Yes
Yes	Yes	Yes
140 x 77 mm	130 x 80 mm	135 mm x 80 mm

Primo® DMSO resistant Peelable seal	Primo® Pierceable seal	Primo® Foil Peelable and Pierceable seal	Primo® Thermal Bond Seal
ECPCR0585 (500 mm)	ECPCR0530 (610 mm)	ECPCR0535 (610 mm)	ECPCR0590 (500 mm)
ECPCR0586 (500 mm)	ECPCR0532 (500 mm)		
ECPCR0587 (#) (125 x 78 mm)	ECPCR0531 (125 x 78 mm)	ECPCR0536 (125 x 78 mm)	ECPCR0591 (125 x 78 mm)
Low/room temperature compound storage with DMSO & other organic solvents	PCR, compound storage, sample shipping	Low temperature compound storage, short-term room temperature compound storage, PCR	Low temperature transportation & storage. PCR (esp. water bath cyclers), Storage of organic solvents, acids & alkalines
Can be peeled directly from -80°C freezer. High resistance to solvents even at elevated temperatures	Easily pierceable. Resistant to DMSO. Re-sealable with another Pierce Seal. Color print identifies non-sealing surface	Re-sealable with another Foil Seal. Colour print identifies non-sealing surface	Very strong seal with PP. Resistant to DMSO and other solvents
-80°C	-20°C	-20°C	-200°C
40°C	120°C	110°C	110°C
No (*)	No (*)	No (*)	No (*)
No	Yes	Yes	No
Yes	No	Yes	Yes
Yes	Yes	Yes	Yes
Laminate	Foil	Foil	Laminate
PP, PE, COC	PP, PS	PP, PS	PP

Tips compatibility chart

Codice	Descrizione	Euroclone Primo®										GILSON					Eppendorf										
		Single Channel					Multi Channel										Research Plus										
		0,1-2 µl	0,5-10 µl	2-20 µl	10-100 µl	20-200 µl	100-1000 µl	0,5-10 µl	5-50 µl	20-200 µl	20-300 µl	0,2-2 µl	0,5-10 µl	2-20 µl	10-100 µl	20-200 µl	100-1000 µl	0,1-2,5 µl	0,5-10 µl	2-20 µl (grey)	2-20 µl (yellow)	10-100 µl	20-200 µl	100-1000 µl			
PUNTALI ECO TIP																											
Rack																											
ETT0010RN	Primo® tips low retention 10 µl racked non sterile	x	x														x	x									
ETT0010RS	Primo® tips low retention 10 µl racked sterile	x	x														x	x									
ETT0200RN	Primo® tips low retention 200 µl racked non sterile			x	x	x								x	x	x								x	x		
ETT0200RS	Primo® tips low retention 200 µl racked sterile			x	x	x								x	x	x								x	x		
ETT1000RN	Primo® tips low retention 1000 µl racked non sterile						x																			x	
ETT1000RS	Primo® tips low retention 1000 µl racked sterile						x																				
Filter																											
ETT0010FT	Primo® ECOTIP filtered, sterile, 10 µl, low retention, racked	x	x											x	x												
ETT0020FT	Primo® ECOTIP filtered, sterile, 20 µl, low retention, racked			x											x	x	x							x	x		
ETT0100FT	Primo® ECOTIP filtered, sterile, 100 µl, low retention, racked				x									x	x	x								x	x		
ETT0200FT	Primo® ECOTIP filtered, sterile, 2-200 µl, low retention, racked					x									x	x	x							x	x		
ETT1000FT	Primo® ECOTIP filtered, sterile, 100-1000 µl, low retention, racked						x											x								x	
PUNTALI PREMIER TIP																											
Filter																											
ECTD00010	Primo® filter tips 0,1-10 µl, Sterile Low retention, racked	x	x				x							x	x								x	x			
ECTD00012	Primo® filter tips 0,2-10 µl, Long, Extra narrow, Sterile, Low retention, Racked		x				x								x	x							x	x	x		
ECTD00020	Primo® filter tips 2-20 µl, Sterile, Low retention, racked			x																					x		
ECTD00100	Primo® filter tips 2-100 µl, Sterile, Low retention, racked			x	x			x							x									x	x		
ECTD00200	Primo® filter tips 2-200 µl, Sterile, Low retention, racked				x	x			x							x										x	
ECTD00300	Primo® filter tips 2-300 µl, Sterile, Low retention, racked					x	x			x						x										x	
ECTD01005	Primo® filter tips 100-1000 µl, Sterile, Low Retention, racked																	x								x	
ECTD01250	Primo® filter tips XL 100-1250 µl, Sterile, Low Retention, racked																									x	
Bulk NS																											
ECTD10010	Primo® tips 0,1-10 µl, clear, bag	x	x				x							x	x								x	x			
ECTD10012	Primo® tips 0,2-10 µl, Long, Extra narrow, clear bag			x				x							x	x								x	x	x	
ECTD10200	Primo® tips 2-200 µl, clear, bag				x	x	x		x	x					x	x	x								x	x	x
ECTD10300	Primo® tips 2-300 µl, clear, bag				x	x	x								x	x	x								x	x	x
ECTD11000	Primo® tips 100-1000 µl, clear, bag																									x	
ECTD11250	Primo® tips XL 100-1250 µl, clear, bag																									x	

Sartorius						Thermo						Rainin															
Proline Plus						Picus						Fimppette 1						Novus					Lite XLS				
0.1-2.5 µl	0.5-10 µl	2-20 µl	10-100 µl	20-200 µl	100-1000 µl	0.2-10 µl	5-120 µl	10-300 µl	50-1000 µl	0.5-10 µl (pink)	0.5-10 µl (yellow)	2-20 µl (yellow)	2-20 µl (turquoise)	10-100 µl	20-200 µl	100-1000 µl	0.5-10 µl	20-200 µl	0.1-2.0 µl	0.5-10 µl	20-200 µl	100-1000 µl					
x	x																		x	x							
x	x																		x	x							
				x											x							x					
				x											x							x					
									x							x							x				
																x							x				
x	x																		x	x							
				x											x							x					
				x											x							x					
				x											x	x						x					
					x																		x				
					x											x							x				
x						x				x								x									
x						x				x			x					x									
		x	x	x			x				x	x		x	x				x								
		x	x	x				x						x	x					x							
					x											x							x				
					x											x							x				



DISCOVER

ALL OUR GUIDES!

Scan the QR Code below to discover all our guides:

- Esosomi
- Car-T
- Sferoidi
- Epigenetica
- Single Cell
- NGS 5.0
- Processi Cellulari
- Sample Preparation
- SARS-CoV-2
- Produzione Terapie Cellulari
- Produzione Proteine Ricombinanti
- Drug Discovery



Some of the brands mentioned in the guides are available through Euroclone only in Italy.



EuroClone
ACADEMY

GUIDA AL MONDO
NGS 5.0

10x GENOMICS | Biotropic | Cell Signaling TECHNOLOGY | sage science | splabtech
 MGI | PARAGON GENOMICS | magtivio | cytiva | Covaris | Lonza
 Zymo Research | BioLabs | BMG LABTECH | IMPLEN | SBI

EuroClone
BIOTECH INDUSTRY

GUIDA AL MONDO
DRUG DISCOVERY

BMG LABTECH | splabtech | eppendorf | CEDARLANE
 Enzo | 10x GENOMICS | greiner bio-one | Cell Signaling TECHNOLOGY | Lonza

EuroClone
ACADEMY

GUIDA AL MONDO
SFERIDI

SBI | Cell Signaling TECHNOLOGY | Zymo Research

PROCESSI CELLULARI

EuroClone
ACADEMY

GUIDA AL MONDO
PROCESSI CELLULARI

Cell Signaling TECHNOLOGY | greiner bio-one | eppendorf
 Lonza | Enzo | cytiva

SINGLE CELL

EuroClone
ACADEMY

GUIDA AL MONDO
SINGLE CELL

10x GENOMICS | Biotropic | Enzo | eppendorf
 CORNING | greiner bio-one | SCIENION | cytiva | Lonza
 PanReac AppliChem | BioLabs | CEDARLANE | Nordmark Biochemicals

GUIDA AL MONDO
SFERIDI

EuroClone
ACADEMY

greiner bio-one | Lonza

PRODUZIONE PROTEINE RICOMBINANTI

EuroClone
BIOTECH INDUSTRY

GUIDA AL MONDO
PRODUZIONE
PROTEINE RICOMBINANTI

EPIGENETICA

EuroClone
ACADEMY

GUIDA AL MONDO
EPIGENETICA

Cell Signaling TECHNOLOGY | Enzo | splabtech

Car-T

EuroClone
ACADEMY

EuroClone®
serving science through innovation

Euroclone SpA
Società a Socio Unico

Via Figino, 20/22
20016 Pero (MI) Italy
T +39 02 38195.1
F +39 02 33913713
M tsa@euroclone.it

www.Euroclone.it

Quality Management Systems and
Environmental certified according to
EN ISO 9001, ISO 13485 and EN ISO 14001

Distributed by

**BIOMEDICA**
www.bmgrp.eu

Molecolare_web_0623_ed2